

# Team Taurus

ESMD Space Grant Systems  
March 2, 2009

*Team Members:*

Charlie Foucar  
Leslie Goldberg  
Bodin Hon  
Shannon Moore  
Evan Williams

*Faculty Advisors:*

Dr. Maria Oden  
Dr. Melissa McHale

*NASA Advisors:*

Dr. Tara Ruttley  
Dr. David Tomko



**BONE REMODELING MONITOR**



**ESMD Space Grant Systems 2009**

Team Taurus



# BONE REMODELING MONITOR

Charlie Foucar, Leslie Goldberg, Bodin Hon, Shannon Moore, Evan Williams

## PROBLEM:

The impact of bone loss due to different mechanical loadings in microgravity is a major concern for astronauts upon reintroduction to gravitational forces in exploration missions to the Moon and Mars. It has been shown that astronauts not only lose bone at differing rates, with levels up to 2% per month, but each astronaut will respond to bone loss treatments differently.

## CURRENT METHODS:

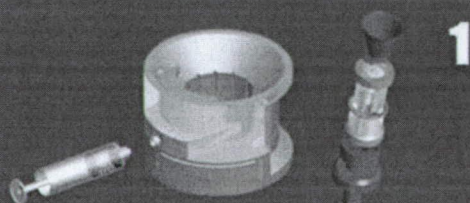
Pre- and post-flight imaging techniques and frozen urine samples for post-flight laboratory immunoassays

## PURPOSE:

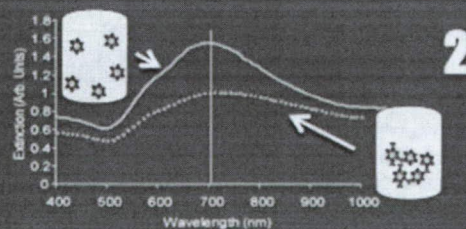
To develop a novel, non-invasive, highly-sensitive, portable, intuitive, and low-powered device to measure bone resorption levels in 'real time' to provide rapid and individualized feedback to maximize the efficacy of bone loss countermeasures.

## SOLUTION:

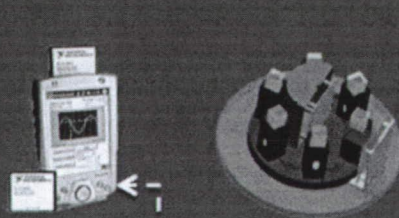
1. Collect urine specimen and analyze the level of bone resorption marker, DPD (deoxypridinoline) excreted.
2. Antibodies specific to DPD conjugated with nanoshells and mixed with specimen; the change in absorbance from agglutination is measured by an optical device.
3. The concentration of DPD is displayed and recorded on a PDA.



Urine Specimen collected from device integrated with the space toilet

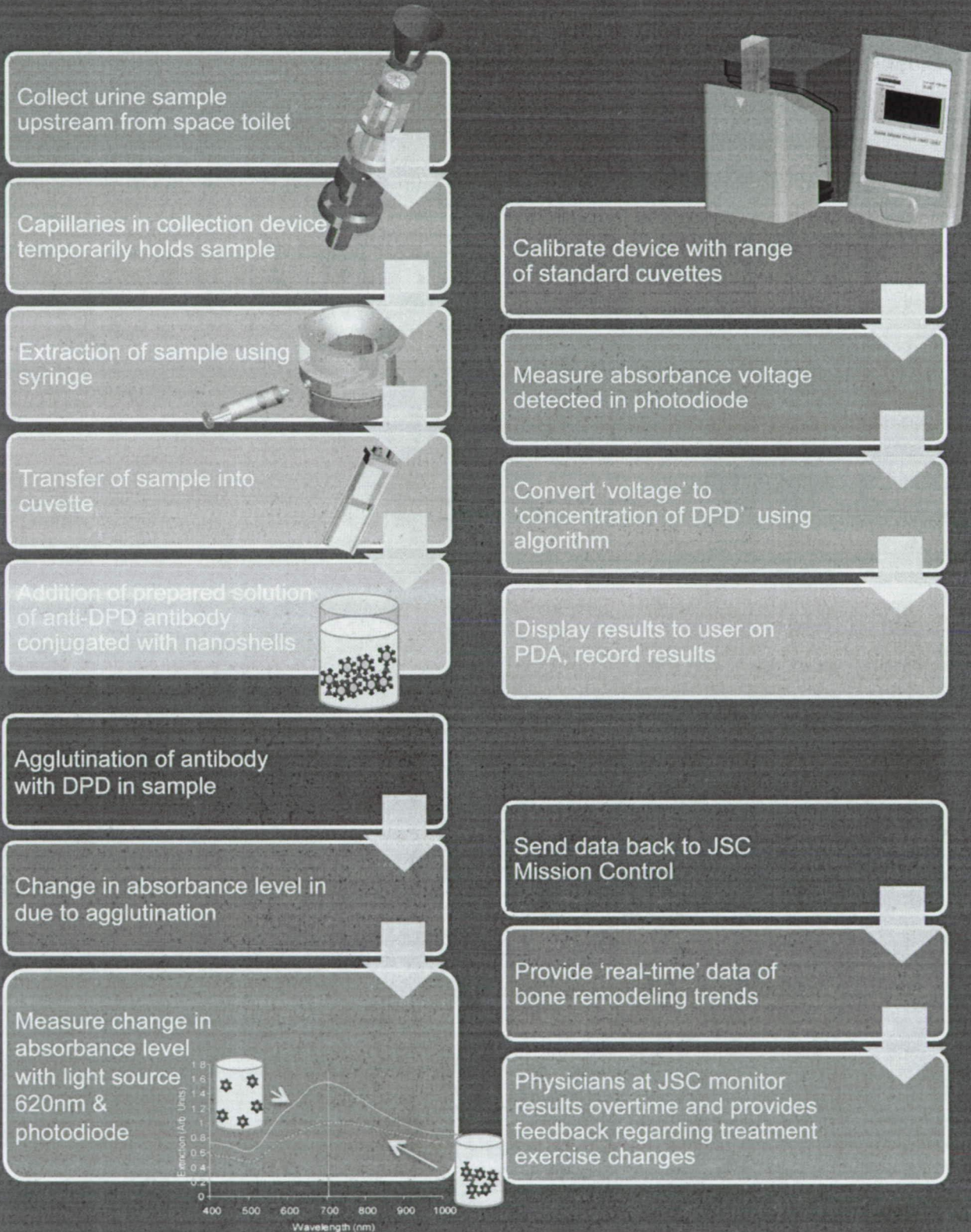


Agglutination of DPD with DPD-specific antibody conjugated with nanoshells causes a change in absorbance level in mixture



Absorbance level measure by an optical device and results displayed on PDA

# SYSTEM FLOWCHART



## Acknowledgements

Team Taurus gratefully acknowledges our mentors and collaborators who have provided invaluable information and feedback in all stages of the design process. Specifically, we would like to recognize our faculty advisors at Rice, Dr. Oden and Dr. McHale, our collaborator from Texas A&M, Dr. Bloomfield, as well as our mentors from the NASA Johnson Space Center, Dr. Ruttley and Dr. Tomko. Additionally, we are appreciative of Debbie Mullins for the coordination of the TSGC design competition. We value the time and effort that has been graciously provided by our mentors and collaborators.

## Executive Summary

Data from orbital missions by NASA have revealed dramatically accelerated bone density loss for astronauts living in microgravity. The NASA bioastronautics roadmap, which encompasses research, operations, and policies related to the risks associated with human space flight have identified that the risk of bone loss is a high priority. The risk rating for accelerated bone density loss for current ISS missions is rated at 2, for future lunar missions it is rated at 3 and for Mars missions rated at 3. Current countermeasures to mitigate bone loss includes nutrition, exercise (resistive and aerobic) as well as crew screening and preparation. However, there is yet to be a method of quantifying bone loss in real-time. Astronauts lose bone at differing rates and respond to treatments differently, so immediate evaluation of bone loss significantly aids bone density treatment and evaluation by providing rapid, individualized feedback.

Team Taurus proposes a countermeasure effectiveness monitoring system which encompasses all forms of current and projected mitigation techniques that NASA employs to prevent bone losses for future missions. Team Taurus has undertaken the building of a novel device for use in space to quantify the real-time loss of bone mineral density. The device is designed to incorporate with NASA's existing waste management system for ease of collection of urine samples, and includes a nanoshell assay that is quickly read using a handheld spectrophotometer.

The test uses a nanoshell conjugation assay followed by spectrophotometric quantification. Urinalysis was chosen for its convenience of use, small size, and accurate results. The device consists of three components: a collective compartment attached to the space toilet, a nanoshell assay for detecting deoxypyridinoline, and a near-IR spectrophotometer to measure the absorbance spectrum from the assay.

The individual components of this device have been specially designed considering the constraints of microgravity, and the needs for accuracy and sustainability as dictated by astronauts in long duration space missions. The overall design of the system encompasses three distinct arenas:

1. Sample collection device, incorporated with the space toilet
2. Gold nanoshell-based assay specific to bone resorption markers
3. A hand-held spectrophotometer and data collection system integrated with a PDA

This document outlines the system engineering procedures as well as the significant steps involved in the design, testing and validation of the individual device components of this system.

# Table of Contents

<b>I. List of Figures</b> .....	<b>7</b>
<b>II. Introduction of Project</b> .....	<b>8</b>
<b>III. Systems Engineering Process</b> .....	<b>9</b>
<i>III.1 Process Planning</i> .....	9
<i>III.2 Design Criteria</i> .....	11
<i>III.3 Project Requirements</i> .....	13
<i>III.4 System design</i> .....	14
Collection device .....	14
Nanoshell assay .....	17
Spectrophotometer .....	20
<i>III.5 Result Verification</i> .....	21
Nanoshell assay .....	21
Spectrophotometer .....	23
<i>III.6 System Analysis</i> .....	24
WBS and Gantt Chart.....	24
Pugh Matrices .....	25
<b>IV. Transitioning Critical Technologies</b> .....	<b>25</b>
<b>V. Integration of Systems Engineering Efforts</b> .....	<b>26</b>
<b>VI. Implementation Tasks</b> .....	<b>28</b>
<b>Cost Effectiveness Analysis</b> .....	<b>29</b>
<i>Cost Estimation and Budget Planning</i> .....	29
<b>VIII. Design Configuration Control</b> .....	<b>30</b>
<b>Cuvette Holder</b> .....	<b>37</b>
<b>IX. Tradeoff Assessment</b> .....	<b>39</b>
<b>X. Risk Analysis</b> .....	<b>40</b>
<b>X. Conclusions</b> .....	<b>41</b>
<b>XI. Appendices</b> .....	<b>42</b>
<i>A. List of Acronyms</i> .....	42
<i>B. Bioastronautics Roadmap Flow Chart</i> .....	43
<i>C. WBS</i> .....	44
<i>D. Flowcharts - Detailed Component Operations</i> .....	45
<i>E. Pugh Matrices</i> .....	48
<i>F. Gantt Charts</i> .....	50
<i>G. Budget Plan</i> .....	53
<i>H. References</i> .....	54
<i>I. Collaborators</i> .....	57

## I. List of Figures

Figure 1. NASA bioastronautics roadmap	10
Figure 2. Overall design process flowchart	10
Figure 3. CAD cross section view of the urine collection receptacle	15
Figure 4. CAD capillary clearing mechanism	15
Figure 5. CAD locking mechanism on urine collection receptacle	16
Figure 6. CAD urine sample extraction method	16
Figure 7. Sample FEA structural analysis	16
Figure 8. Sample CAD-integrated fluid analysis	17
Figure 9. Optical resonance behaviour of a 60 nm core nanoshell	17
Figure 10. Plot of change in extinction spectrum as a result of nanoshell agglutination	18
Figure 11. Representation of finalized gold nanoshell	19
Figure 12. Spectrophotometer prototype setup	20
Figure 13. LabView Graphical User Interface displayed on PDA	20
Figure 14. LabView block diagram for spectrophotometer	21
Figure 15. Plot of nanoshell spectrum in a salt solution	23
Figure 16. Absorbance vs. Concentration plot for spectrophotometer functionality test	24
Figure 17. Overview of process schedule	26
Figure 18. Team organizational flowchart	27
Figure 19. Cost engineering, budget	29
Figure 20. CAD Initial ideas for collection device	30
Figure 21. CAD collection device configuration 2.0	31
Figure 22. CAD honeycomb clearing mechanism	32
Figure 23. CAD cross section view of the urine collection receptacle	32
Figure 24. CAD collection device configuration 2.1	33
Figure 25. CAD collection device configuration 2.1, locking mechanism	33
Figure 26. CAD spectrophotometer 1.0, isometric view	34
Figure 27. CAD fluid retention method of urine sample collection receptacle	34
Figure 28. CAD spectrophotometer 2.0, rotating carousel	35
Figure 29. CAD spectrophotometer 3.0	36
Figure 30. CAD spectrophotometer 3.0, movement track and pin	37
Figure 31. CAD spectrophotometer 3.0, cuvette holder	37
Figure 32. PDA/spectrophotometer interface	38
Figure 33. Technical risks of each component	40

## II. Introduction of Project

One of the major concerns of long-term space travel is the significant decrease in bone mineral density resulting from the microgravity environment. The weightless conditions unload much of the skeletal stress, leading to significantly decreasing levels of bone mineral density (BMD) recorded in specific load-bearing bones. Similar to the effects of osteoporosis, microgravity-induced BMD loss increases the risk of bone fracture, with the deleterious effects being magnified as the duration of the mission increases.

NASA's current treatment methods, including supplements and exercise regimens, offer some mitigation of the effects of microgravity but are insufficient for space travel exceeding one year. Thus the rate of bone loss in microgravity presents a significant technical hurdle to long duration missions such as the manned mission to Mars. Although NASA is currently exploring a plethora of ideas to eliminate bone loss in astronauts, NASA has no method to quantify the efficacy of current and experimental treatments in real-time. Instead, NASA measures the bone loss before and after missions. This method neglects the time dynamics of bone loss and fails to provide ground control with real-time feedback of the results of bone loss treatment.

The proposed solution is a portable and non-invasive device for measuring systemic BMD loss as indicated by levels of deoxypyridinoline (DPD), a bone-specific resorption marker found in urine. Many commercially available urine assays utilize DPD to measure bone loss because of both its specificity to bone and its resistance to interference from outside factors. The concentration of DPD in urine will be quantified using a novel gold nanoshell-based immunoassay. This method has been previously used to quantify solute concentration by measuring the decrease in absorption at a wavelength specific to the gold nanoshells. Gold nanoshells have unique optical properties that lead to a measurable decrease in absorption when nanoshells agglutinate around a target solute. Therefore, the use of gold nanoshells with conjugated anti-DPD will provide a characteristic emission spectra based on the agglutination of the sample. Thus by utilizing a portable spectrophotometer, precise concentrations of the bone resorption marker can easily be assessed in a rapid manner.

Real-time feedback on the successes of attempted BMD loss treatments will allow NASA to understand the dose-response of these treatments. After analysis of the results, physicians can modify the treatment as necessary to tailor astronaut-specific regimens to minimize bone loss. The proposed device will measure systemic BMD loss in real-time to provide valuable data towards minimizing the deleterious effects of microgravity on bone density. In the following paper, one can view the technical specifications of this device as well as the design process used in its development.



### III. Systems Engineering Process

#### III.1 Process Planning

As summarized by the NASA Bioastronautic roadmap (see figure 1), there are five main categories of health related issues that could be encountered by astronauts in microgravity. These are then further divided into 16 disciplines for researchers and scientists to answer. Team Taurus' bone remodeling monitor system falls into the bone loss discipline where accelerated bone loss and fracture risks are identified as a Level 2 priority risk for ISS, Lunar and Mars missions. Current countermeasures include nutritional supplementation, exercise (resistive and aerobic), and crew screening and preparation. Projected countermeasures for this risk includes: biophysical modalities, crew screening, exercise and fitness regimes, hormone replacement therapy, nutrition, pharmacological (biphosphates), rehabilitation strategies, spacesuit design and artificial gravity.

Team Taurus has envisioned a system to track and monitor bone loss in real time to potentially minimize the effects of microgravity on the skeletal system through more informed management. The team has designed a four cycle project plan for the technical aspect of the system (see figure 2). Currently, in cycle three, the team is testing and refining a prototype for the system. At each level, the decision was made using Pugh analyses to provide a quantifiable method of decision making based on weighed importance of design criteria (see appendix E). The configuration control details the design stages of each component of the system. The next step of this project is to implement a new procedural operation on NASA missions to govern the utilization of the bone remodeling monitor.

The overall process flowchart is depicted in figure 2. The top level for the process is a broken down into the four stages of development. Each cycle is expanded with further detail on the right. Initially the problem is clearly defined and the need for a new system is justified. A general literature search and review are conducted to identify past and present solutions utilized in space missions as well as on earth. These methods are then evaluated for performance, cost and feasibility using Pugh analysis to further develop the highest rated methods. Subsequently, a refined literature search is conducted to launch the project development into the second cycle- the development of the solution. Design criteria are explicitly determined based on environmental and operational constraints. The project team will seek expert consultation to refine the project development. The proposed solution will be partitioned into multiple components that can be developed and optimized separately to maximize efficiency (see appendix D for flowcharts of detailed component operations). As each component is modified it will be tested against the measurable design criteria until all criteria are satisfied. When each component is fully optimized, the system will be assembled and be further tested as a complete system. System analysis, including detailed cost, failure, safety, hazard and performance, will be conducted before the project design is complete.

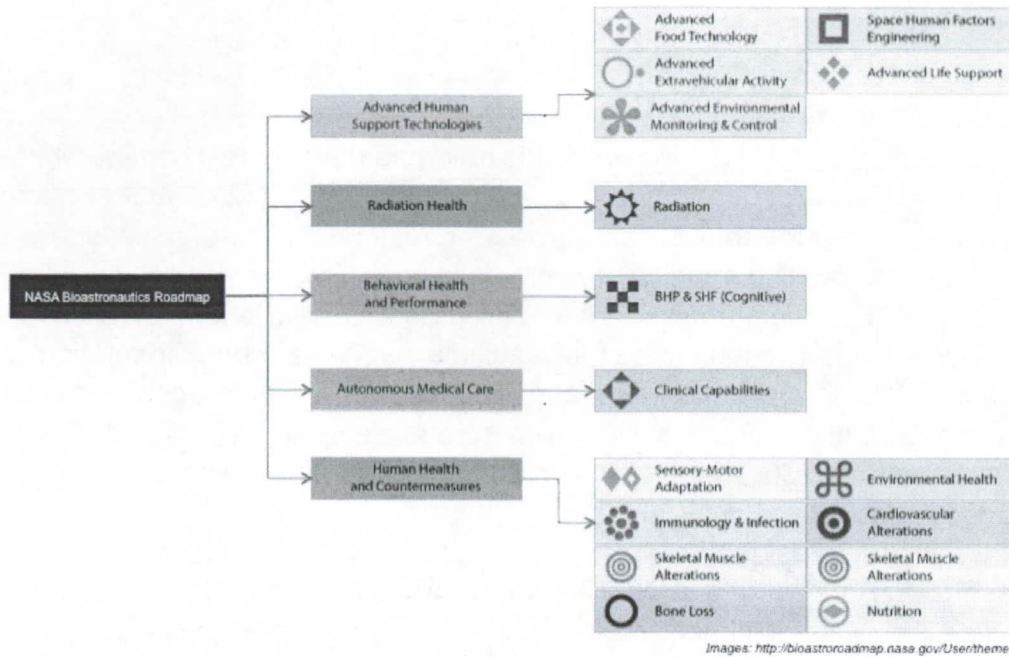


Figure 1. NASA Bioastronautics Roadmap shows the administrative division of this system under the Human Health and Countermeasures discipline.

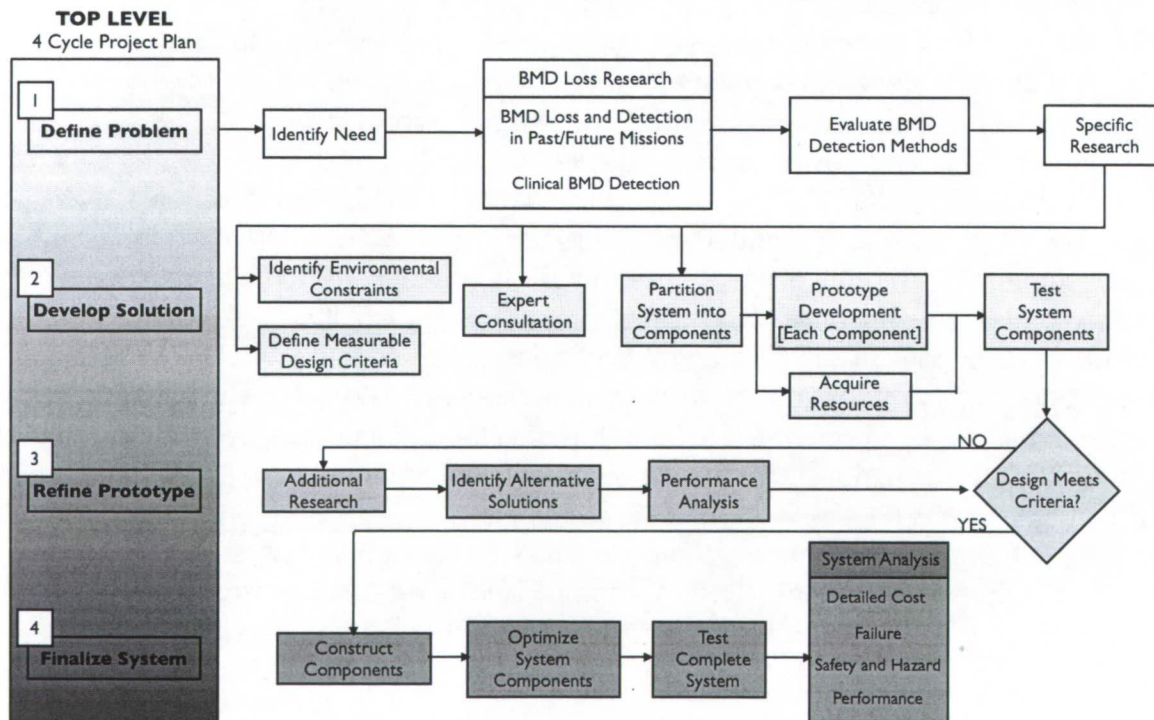


Figure 2. Design flowchart for the development of the bone density loss system.

### **III.2 Design Criteria**

To most accurately monitor bone loss, measurements must be taken for each astronaut multiple times during a week. During normal use, an astronaut will attach his collection funnel to the space toilet and rotate the collection device to expose the honeycomb capillaries to the suction pressure. This allows a small stream of urine to be diverted into the pore spaces, which is then extracted with a syringe. The astronaut then transfers the sample to a cuvette where the urine containing bone markers combines with nanoshells coated with antibodies against the bone marker. Next, the cuvette is capped and placed into the sample holder of the spectrophotometer, which reads the attenuation in spectral properties of the sample. The astronaut has the option to manually record the level of his bone loss, or collect the data on an integrated PDA, which stores each astronaut's history and allows the data to be transmitted back to physicians on earth. Based on the rate loss data, experts will then tailor exercise regimes and dietary supplements to minimize the rate of bone mineral density loss of each individual astronaut.

The following design criteria were chosen based on the restrictions implicit with space travel. The primary motivators for these criteria were crew operation, device complexity, and durability. For each criterion, a desired value and method of testing the prototype is specified by which the success of the design will be judged.

Design Criteria	Testing Method
Mass under 20 kilograms	Scale
Volume under 30 cm <sup>3</sup>	CAD volume analysis
Training time under one day	Time training of a user with no previous experience
Operating time under five minutes <sup>1</sup>	Time designers' test runs
Able to be dismantled and reassembled in space	Test assembly with tools available from NASA on a KC-135 zero-g simulator flight or consult astronaut with work experience in microgravity to report on feasibility
One device services all astronauts <sup>2</sup>	Test device five times on two subjects
Device digitally tracks all results <sup>3</sup>	Successful if able to link device to data storage system
Device gives repeatable results	Five consecutive tests over one day vary by less than 10%
Device gives accurate results	Tests have r <sup>2</sup> greater than 0.95 compared to DXA measurements
Device withstands five years of use <sup>4</sup>	Extrapolate using accelerated wear & tear test
Withstands zero-g and high-g situations	Device does not break in centrifuge or KC-135 zero-g simulator flight
Withstands pressure standard inside a space vessel	Device operates at sea level atmospheric pressure
Runs on ship's power supply or rechargeable battery	Device uses 28 or 120-160 volt DC, as specified by NASA.
Material should not be volatile	Materials are on NASA-approved list
Non-invasive procedure <sup>5</sup>	Device works with sweat, urine, or saliva

<sup>1</sup> "Operating time under five minutes" signifies that the time the user interacts with the device to obtain a single measurement should be less than five minutes—this does not include analysis time, only the direct attention time required of the user.

<sup>2</sup> "One device services all astronauts" implies all astronauts on the mission can measure their bone density with the same device.

<sup>3</sup> "Device digitally tracks all results" signifies that the device has integrated software and enough storage to track four measurements a week per astronaut for a five-year duration. Device will be RAIDed and backed up for data loss protection.

<sup>4</sup> "Device withstands five years of use" entails a durability tested by simulating the number of tests the device would experience during one space mission. The wear and tear associated with additional space missions may be extrapolated as necessary. Additionally, an accelerated time test will ensure that the internal mechanics of the device remain stable following the vibration of launch and could include lab vibration and sustained g-force testing.

<sup>5</sup> "Non-invasive procedure" denotes that the device will analyze a physiological sample obtained in a non-invasive way and testing will not be harmful to the astronauts' health in any way. Non-invasive testing includes the possibilities of QUS (qualitative ultrasound) or DXA (dual energy X-ray absorptiometry) density scans, urine testing or sweat testing, but excludes collecting any blood samples.

### III.3 Project Requirements

Team Taurus is tasked with the development of a device that measures bone loss over the course of long duration missions. The team's budget for the year is \$2075.00 and the goal is to develop a functioning prototype. The prototype will operate in the laboratory and fulfill the design criteria outlined in the previous section. Ideally, the prototype will be the first step in the development of a device that will accompany astronauts during sustained space missions. The data provided by the device will increase the efficacy of current and future treatments of bone loss in microgravity. Project requirements were assigned to each component of the device based on the constraints of microgravity and user operational requirements.

#### Physical Requirements

- *Device Portability:* The device must be lightweight and portable. Its mass must be less than 20 Kg and its total volume has to be less than  $\text{cm}^3$ . To test these design criteria, a scale will first be used to measure the final weight of the prototype. A CAD model of the device will then be used to calculate the total volume.
- *Non-Invasive:* The device will utilize urine as the fluid for analysis.

#### Usability

- *Short User Training Time:* The time required to train a person unfamiliar with the device to adequately operate the device must be less than one day. This criterion will be verified using test-training sessions.
- *Short Operation Time:* The time it takes the user to collect a urine sample and operate the LabView program on the PDA should be less than five minutes. This does not include analysis time, only the direct attention time required of the user. This will be tested with users trained to use the device before operation during the mission.
- *Robustness:* The PDA must have a backlight and be easily rebootable in the event of a program error.

#### Device Characteristics

- *Device Reassembly:* Astronauts must be able to disassemble and reassemble the device in space using the available tools. The plan is to test assembly with tools available from NASA on a KC-135 zero-g simulator flight (if possible) or consult astronaut with work experience in microgravity to report on feasibility.
- *Device Repeatability:* To yield accurate bone density measurements, the device must be repeatable. This criterion will be assessed by using five consecutive measurements of one sample over one day and verifying that the measurements do not vary by more than 10%.
- *Device Accuracy:* To verify the accuracy of the device, the linear relationship derived from the gold nanoshell based immunoassay must have an  $r^2$  greater than 0.95 compared to laboratory spectrophotometer measurements of the same samples.
- *Data Analysis and Storage:* The PDA must have integrated software for data analysis and enough storage to track four measurements a week per astronaut for a five-year duration. The PDA must be able to upload data to the onboard computers using a Bluetooth uplink.

- *Materials:* All the materials used in the components of the device must be listed on the NASA-approved materials list, which will be verified during development.
- *Life Cycle:* The device must be able to withstand five years of use. This criterion will be tested by extrapolating data from accelerated wear & tear tests.
- *Battery Life:* The PDA must be able to power the device for at least 2 hours without charging. This will be evaluated by timing the maximum time the PDA can power the device.

### Urine Collection

- *Space Toilet Integration:* The urine collection device must integrate into the space toilet and utilize the pressure found in this system to collect a urine sample.
- *Safety:* The device must safely collect a urine sample without subjecting astronauts to the discomfort of urine exposure.
- *Urine Transfer:* The user must be able to transfer urine from the collection device to the analysis device.

### Environment

- *Function in Microgravity:* The device must function in microgravity. If possible, this criterion will be tested on the KC-135 zero-g simulator or otherwise assessed analytically.
- *Vibration:* The device must withstand the vibration and forces of the vehicles entrance into earth's orbit. This criterion will be tested using a centrifuge to apply calculated forces to the device.
- *Power Supply Integration:* The PDA must be able to recharge using the ship's power supply. The device will be designed to use 28 or 120-160 volt DC, the current power supply found on the shuttle.

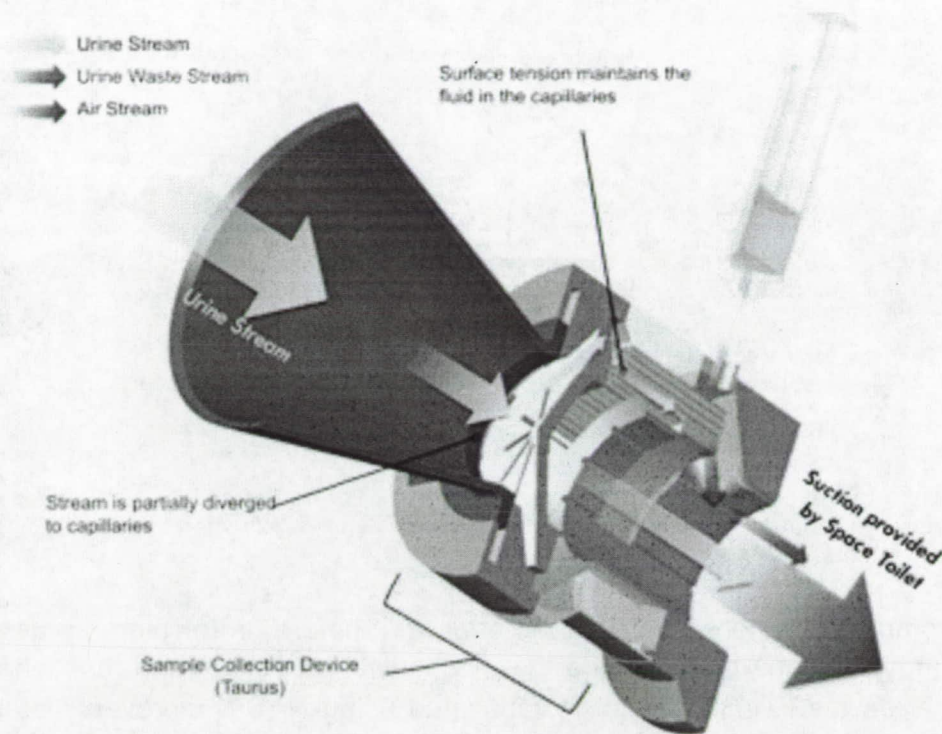
## III.4 System design

### Collection device

The urine collection receptacle is designed to temporarily store and collect urine sample from astronauts in microgravity. This feature is required, as fluid behaves differently in microgravity; the biggest problem is that fluid will not stay inside an open-top container unless pressure is applied to keep the fluid contained. Current waste urine collection is performed using a suction based space toilet— either the NASA Waste Collection System (WCS) or the Russian ACY, whereby a hose with airflow is provided. This collection device will be inserted at the beginning of the hose to take urine samples from the incoming stream.

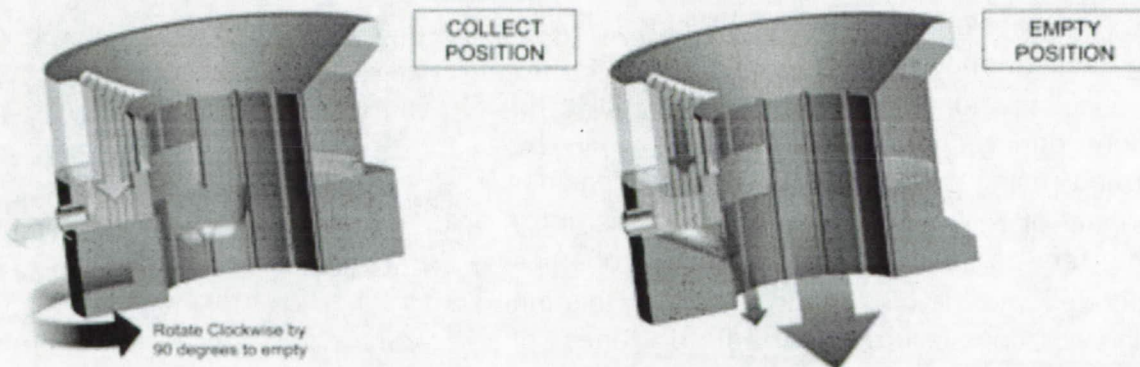
The device will divert a fraction of the incoming fluid stream to be temporarily stored (Fig. 3) until micturition is completed. The urine is able to be temporarily stored in the collection chamber due to the capillary action of the aluminum honey comb insert, which is a bundle of interconnected capillaries, providing a large amount of surface area for capillary action. Capillary action occurs when the relative attraction between the liquid and a solid is stronger than the cohesive intermolecular forces inside the liquid. In microgravity, this phenomenon is

more significant as the lack of gravity can draw the liquid to a much greater length, as gravitational forces balance the effects of capillary forces on Earth.

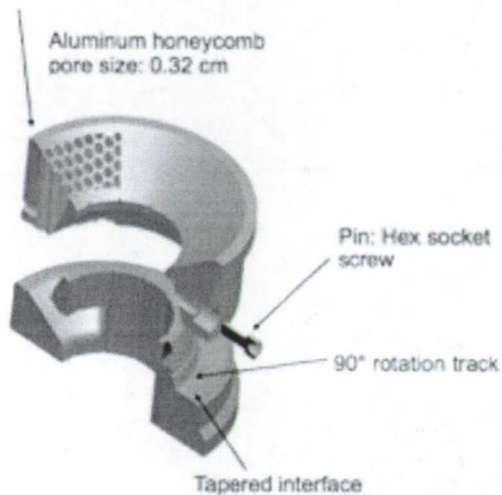


**Figure 3.** Cross section view of the urine sample collection receptacle integrated with the space toilet. Fluid flow and airflow are shown.

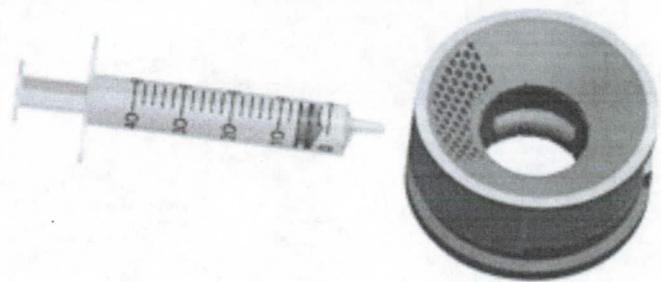
A locking mechanism has been added to prevent the escape of liquid during collection (Figs. 4 and 5). The astronaut will then extract the sample using a syringe, where the pressure from within the syringe will pull the fluid out of the capillaries and the collection chamber (Fig. 6). In addition, a capillary-clearing mechanism (Fig. 4) has been included in the design to simplify the operation of the urine collection receptacle.



**Figure 4.** The urine sample collection receptacle utilizes the airflow from the space toilet to clear the remaining fluid in the capillaries.



**Figure 5.** Locking is achieved by the use of a locking pin and a tapered interface between the components.



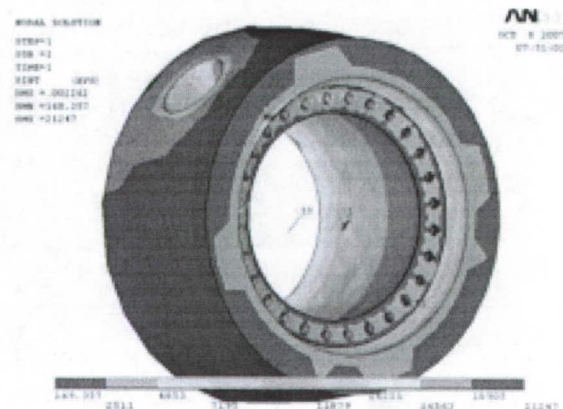
**Figure 6.** The urine sample is then extracted through a port using a syringe.

The sample collection device will be analyzed, before prototyping, by using a series of computational simulations to determine the mechanical properties and functionality to reduce cost. The final device is intended to be fabricated using NASA approved materials, such as titanium for the collection device. Due to this, and the difficulty inherent in testing the design of this device to function in microgravity, this device will not reach the advanced stage of testing given the resources available. However, performing finite element analysis (FEA) and computational fluid dynamics analysis on the CAD model of the device will yield sufficient data to evaluate whether the device has met the design criteria.

#### *Vibrations & structural analysis*

Since the device is intended for use onboard the Orion Crew Exploration Vehicle (CEV), the device was designed to avoid structural failure during launch and landing, as the device may experience up to 3g's of force and 60Hz of vibration during these events. FEA will be performed using the COSMOSWorks Designer component of SolidWorks with the CAD assembly of the device with the material properties incorporated into the model (Fig. 7). Using this the buckling/vibration failure test tool, a series of mechanical tests can be performed to determine whether the device meets the design criteria.

For this test, the CAD file of the device will be tested for vibrations at 5g, which is greater than



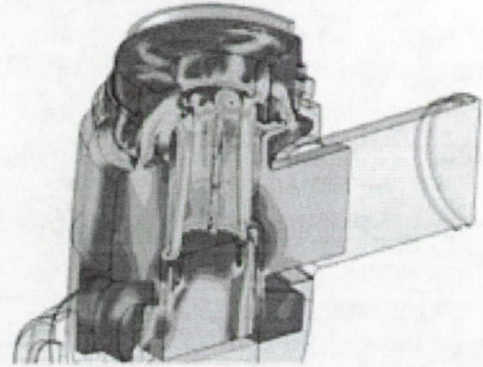
**Figure 7.** FEA structural analysis performed on a device similar to the sample collection device. Source: <http://www.advme.com/channel.jpg>



the 3g of vibration that occurs during shuttle takeoff. If no failures are detected with the software, the device is expected to withstand the vibrational forces of takeoff. [Solidworks, 2008]

### Fluid flow

Testing will have to be performed on the device to determine whether fluid will flow into the collection chamber because the cost of developing an ideal prototype is prohibitive. The flow through the inner pathways of device will be determined using computational fluid dynamics (CFD) analysis rather than physical testing. Analysis will be performed using CAD-integrated fluid flow software such as FloEFD or SolidWorks Flow Simulation (Fig. 8). These tools allow the exact fluid pathway through the device to be determined, as well as identifying more advanced properties such as the velocity of the fluid at every point along the device profile. As shown in the example (Fig. 6), the colored regions show the fluid pathway through a similar device. A maximum entrance flow of 21mL/second is assumed, and the fluid flow into the collection device is assessed at this rate. A calculated flow rate of 0.1 mL/second or anything higher utilizing the CFD will be considered a success. If the calculated value is less, the number of collection capillaries in the device will be increased [FloEFD, 2008].

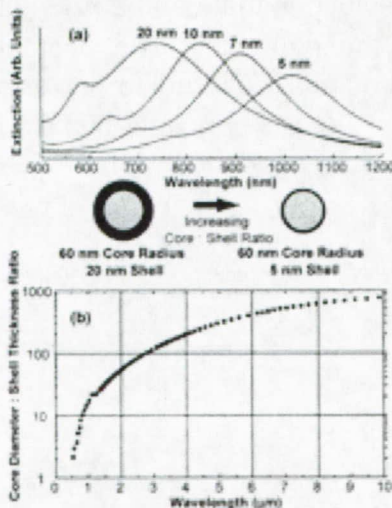


**Figure 8.** CAD-integrated fluid analysis showing flow and velocity distribution in a valve similar to the collection device's.

Source: [www.flowmerics.com/files/casestudies/1069/johnson\\_design\\_02.jpg](http://www.flowmerics.com/files/casestudies/1069/johnson_design_02.jpg)

### Nanoshell assay

Gold nanoshells are nanometer-scaled shells of gold colloid coating surrounding a silica core. Gold is selected as the metallic coating for its inertness and resistance to corrosion [Hirsch]. By altering the ratio of the silica core to the gold shell coating, the Plasmon resonance frequency of the nanoshell can be tuned to specific optical absorption and scattering [Hirsch, 2006]. Nanoshells can be fabricated to cover the visible spectrum as well as the near infrared spectrum from approximately 500 – 1300 nm, where optical transmission through tissue and fluids is optimal (Fig. 9) [Hirsch, 2008].



**Figure 9.**

*Top:* Demonstration of optical resonance dependence on core radius/shell thickness for a 60 nm core.

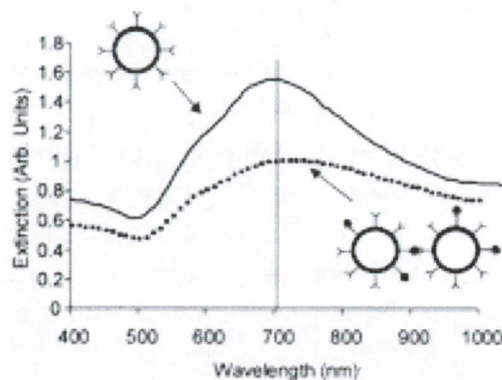
*Bottom:* Optical resonance wavelength versus core radius-shell thickness ratio [Oldenburg, 1998].

To utilize this technology for a DPD assay, conjugation of anti-DPD antibodies to nanoshells will provide the same specificity of the ELISA test, but will minimize the complicated procedural aspects. Specifically, a prepared solution of conjugated nanoshells can be introduced to the analyte solution, then incubated for a short period of time, and analyzed using a spectrophotometer with an excitation LED and absorption photodiode tailored to the nanoshells' Plasmon resonance frequency. The agglutination of the antibody-conjugated nanoshells in presence of the analyte has been shown to cause a decrease in the extinction spectrum, which is easily detected using a spectrophotometer (Fig. 10) [Hirsch, 2006]. This spectral decrease is linearly related to analyte concentration by Beer-Lambert's Law and can therefore be used to calculate the concentration of analyte in solution.

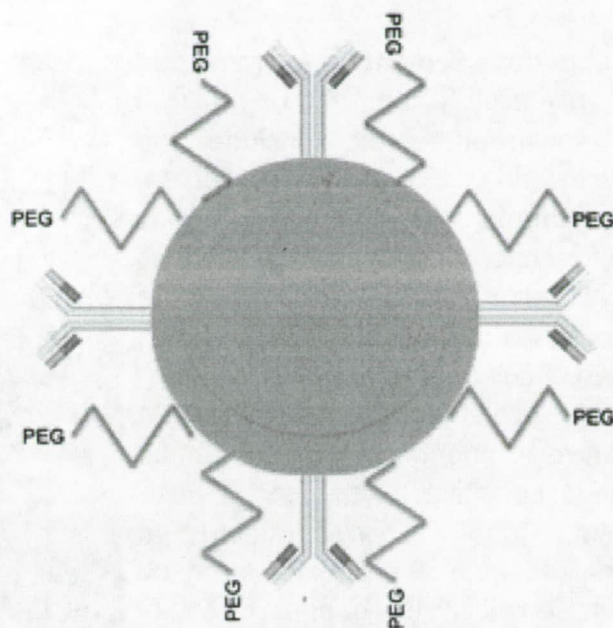
Nanoshells were synthesized using the method of Hirsch et al. [Hirsch, 2006], involving the synthesis of silica cores that were approximately 60nm in diameter. These cores were then covered in a gold shell approximately 7nm in thickness using a 1-3nm gold colloid solution. According to laboratory standards, the synthesized nanoshells were diluted to the point where the measured maximum absorbance was 1.6.

Once the nanoshells are synthesized, anti-IgG antibodies are attached with the electrostatic interactions between the antibodies and the gold coating. Anti-IgG antibodies were chosen because of their low cost and their ability to act as a proof of concept. The optimal antibody concentration was found by preparing a range of nanoshell solutions with different concentrations of antibody and measuring the absorbance spectra of these solutions. The concentration that yielded the highest peak absorbance was selected as the optimal antibody concentration. This optimal antibody concentration was 10  $\mu\text{L}$  of a 0.02 mg/ml solution.

Next, a PEG-SH coating was added to the outside of the nanoshells bound to antibodies. This coating both protects the nanoshells against salt solutions that can be harmful to nanoshells and helps hold the antibodies to the surface of the nanoshell. The optimal concentration of PEG-SH solution was found using the same procedure utilized to find the optimal concentration of antibody solution. The measured optimal PEG-SH concentration was 24  $\mu\text{L}$  of a 10  $\mu\text{M}$  solution. The final result was an antibody conjugated nanoshell with a PEG-SH coating (Fig. 11).



**Figure 10.** Decrease in extinction spectrum as a result of nanoshell agglutination [Hirsch, 2006].



**Figure 11.** Representation of finalized gold nanoshell with silica core, gold coating, conjugated antibodies, and PEG-SH coating.

The finalized gold nanoshells have a peak absorbance at 630nm, the color red in the visible spectrum. Therefore, the spectrophotometer will measure the absorbance at this wavelength and determine the concentration of the analyte by using the data from a previously measured calibration curve.

Progress with the assay has included nanoshells fabrication and antibody and PEG optimization levels. First, gold nanoshells with a silica core were synthesized with a peak absorbance at 630 nm. The optimal PEG coating was determined to be 24  $\mu\text{L}$  of 10  $\mu\text{M}$  stock per 1 mL nanoshells at 1.6 Abs. Antibody optimization has been pursued using less-expensive Anti-IgG instead of anti-DPD for the bone marker. The optimal antibody concentration was optimized at 10-15  $\mu\text{L}$  of 0.02 mg/mL anti-IgG stock per 1 mL 1.6 Abs nanoshells.

For complete synthesis, the antibody is allowed to react with 1 mL of 1.6 Abs, and incubated for 1 hour. Then PEG is added to fill in gaps between antibodies, effectively coating the entire surface of the nanoshell to prevent breakage in salt solutions such as urine.

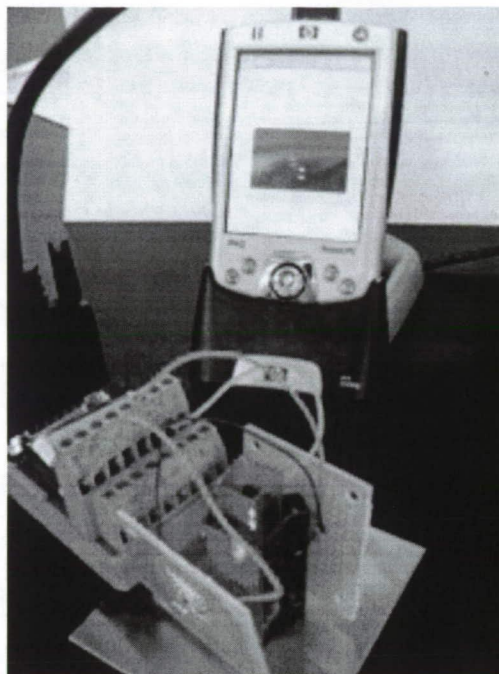
## Spectrophotometer

Spectrophotometer development has proceeded to the first round of prototyping. The physical components of the spectrophotometer include the electronic circuitry with an LED and photodiode, handheld PDA for measurement storage and analysis, and the LabView code for voltage-concentration relations established through calibration. After the samples are prepared they are placed into the cuvette holder, shown in black between the two circuit boards (Fig. 12).

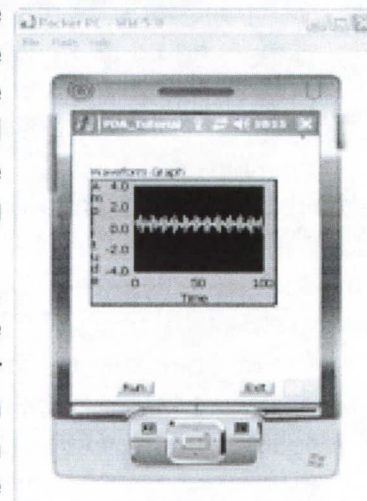
This circuit outputs a voltage value from -2 to 2 V, and is extremely sensitive to changes in concentration; the spectrophotometer is sensitive to changes in the thousandths of volts, ideally corresponding to concentration changes less than 1/100<sup>th</sup> of a percent. Initial tests have shown sensitivity to changes in 5% of the concentration, but no samples were prepared for more sensitive tests.

The current program (Fig. 13) displays the voltage output. Once a correlation between voltage, nanoshell concentration, and metabolite concentration in the sample is determined, more complicated analyses can be quickly added via the LabView programming interface. The PDA supplies power for the spectrophotometer, and the entire system can be self-contained once prototyping is complete. The device is sensitive to ambient light, so a cardboard box is placed on top of the spectrophotometer to eliminate light from outside sources. An aluminum box with a flap for opening and swapping out samples has been designed for this purpose.

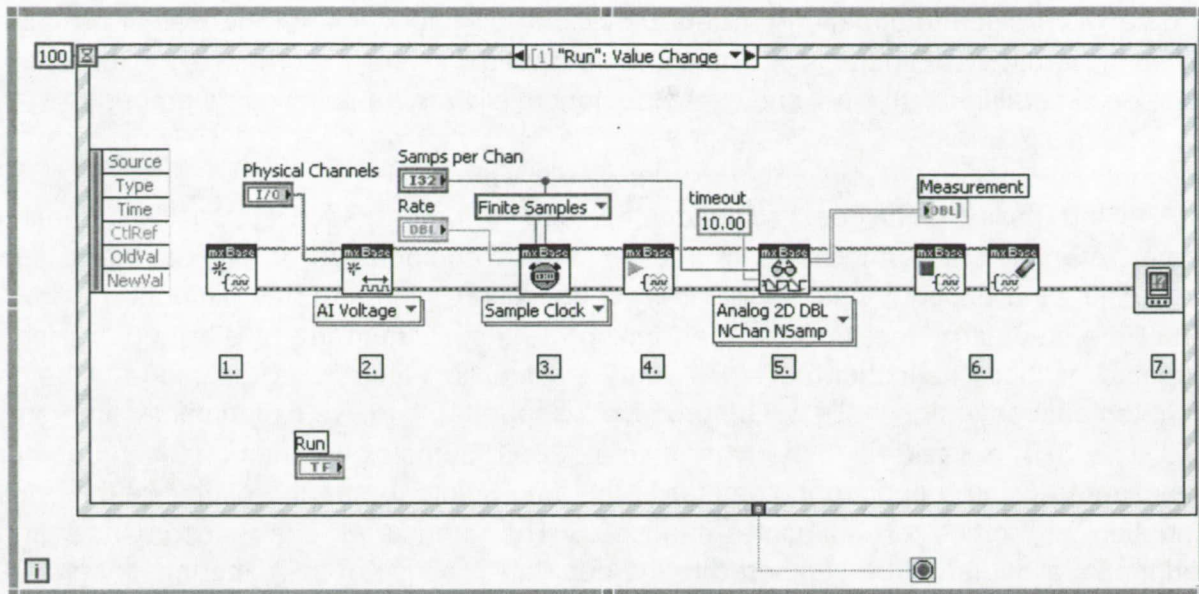
The LabView code (Fig. 14) uses standard mobile unit VI's, which are adapted from the full VI set. The program is a voltage reader, providing a graph of the voltage reading and options for changing the sampling rate of the reading, as well as the read-in channel. This provides a quantifiable view of the reading from each sample. The reading is then recorded, and more samples may be tested to analyze differing concentrations of nano-particles.



**Figure 12.** Spectrophotometer setup. Cuvette in holder between LED and photodiode circuits. Cables and connector block with PDA as user interface.



**Figure 13.** LabView User Interface displayed on PDA



**Figure 14.** LabView block diagram of the voltage reader code. Information is read in through a mobile DAQ-mx set; other VIs provide the controls and create the output graph.

The PDA is then connected via Bluetooth to a laptop running Microsoft Windows, where the data are synchronized and saved. As NASA space operations include laptops and PDAs by standard, this will require no additional room on the shuttle or station, and it will allow the program to be modified in-flight should the need arise.

### III.5 Result Verification

#### Nanoshell assay

##### *Verification of antibody-nanoshell conjugation*

Since the antibody-based nanoshell assay technique for measuring bone marker concentration is a fairly new technique, verification by a commercial spectrophotometer will be performed.

Images of the nanoshell solution will be taken using a scanning electron microscope. These images will be compared to previous images taken by the Drezek lab at Rice University to verify the presence of both the PEG coating and antibodies. If the amount of PEG coating or the number of conjugated antibodies appears too low, the concentration of PEG-SH solution and antibody solution will be increased accordingly.

##### *Verification and characterization of nanoshell function*

Rabbit IgG is to be dissolved into 100mM phosphate buffered saline (PBS) at 2.2, 1.1, 0.22, 0.11, 0.022, and 0  $\mu\text{g}/\text{ml}$ . The nanoshell solution will then be diluted to  $1.83 \times 10^9$  particles/mL using DI water 0.20  $\mu\text{L}$  of the rabbit IgG solution will be aliquoted into 480  $\mu\text{L}$  of the nanoshell solution. After 5, 10, 15, 20, 25, and 30 minutes the absorbance spectra of all of the samples will be measured. This experiment should yield a calibration curve where the absorbance decreases somewhat linearly relative to the concentration of IgG in the solution.

This data will provide information on data precision and show how the nanoshells should be modified accordingly. If there is no measurable change in the absorbance for the different experimental conditions, this will show that the nanoshells are not functioning properly.

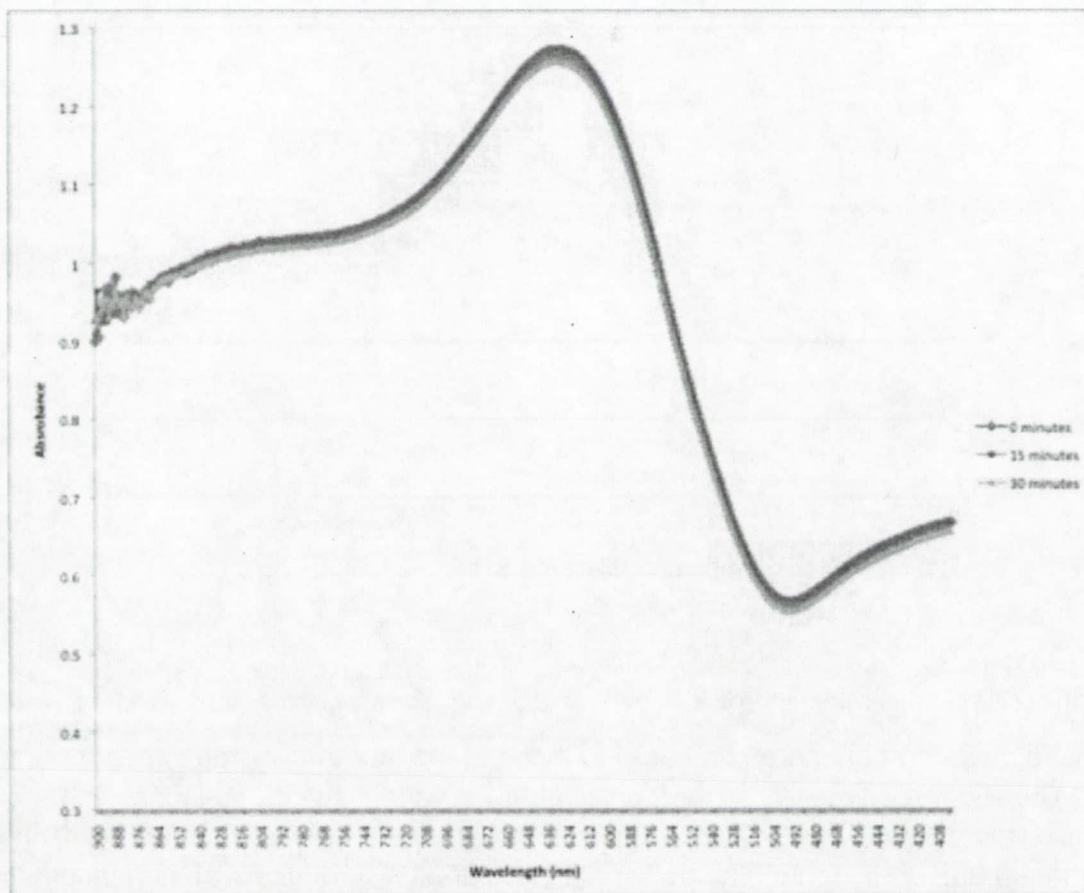
#### *Functionality of conjugated antibody-nanoshells over time*

As this assay technique is intended for use in long-duration space flight, there are concerns over the long-term viability of the biochemical components. To combat this, a supply of pre-conjugated antibody-nanoshell pairs will be frozen and stored as aliquots to eliminate much of the crew time necessary for performing the test. Testing the feasibility of storing the conjugated antibody-nanoshell pairs will verify the functionality of this technique. A batch of conjugated antibody-nanoshells will be produced, separated into five experimental time groups (e.g. 0, 1, 2, 3, 4, 5 weeks) and then stored in at -20°C. Samples will then be taken out, mixed and measured using a spectrophotometer at the time points to see the effects of time on the conjugation properties of antibodies-nanoshell. The measured peak absorbance of the experimental aliquots will be compared to the peak absorbance of the experimental groups to verify no significant decrease in absorbance. A significant decrease in absorbance is indicative of a breakdown of nanoshell structure. If there is deviation from the original absorbance, the procedure in which the nanoshells are stored will be modified. Since fresh batches of antibodies-nanoshell are typically made in laboratory studies, there are no data on the functionality of these biochemical particles after long duration freezing.

#### *Test for nanoshell viability in salt solution*

Salt solutions are known to be detrimental to nanoshells. Because the gold nanoshell based immunoassay will be used to measure the concentration of DPD in urine, since urine is a salt containing fluid, there is a need to test the viability of the synthesized nanoshells in a salt solution environment. To test this variable, a nanoshell solution will be diluted in DI water until the peak absorbance is 1.6. This solution will then be centrifuged for 15 minutes at 3000 rpm. Afterwards, the nanoshells will be suspended in 1mL of 1XPBS. The absorbance spectrum of this solution at 0, 15, and 30 minutes will be measured using a laboratory spectrophotometer. If there is little variation in the absorbance spectra, then the nanoshells are stable for a sufficient period of time in the salt solution. If, however, there is variability > 10% in the maximum absorbance in the spectra, the experiment will be repeated by synthesizing nanoshells with a greater concentration of PEG-SH. This greater concentration of PEG-SH will hopefully help to protect the nanoshells from the salt solution.

When the experiment was conducted, no significant variation in the spectra over the course of 30 minutes was observed (Fig. 15). The results of this experiment therefore indicated that the nanoshells will be functional in a salt solution such as urine for at least 30 minutes.

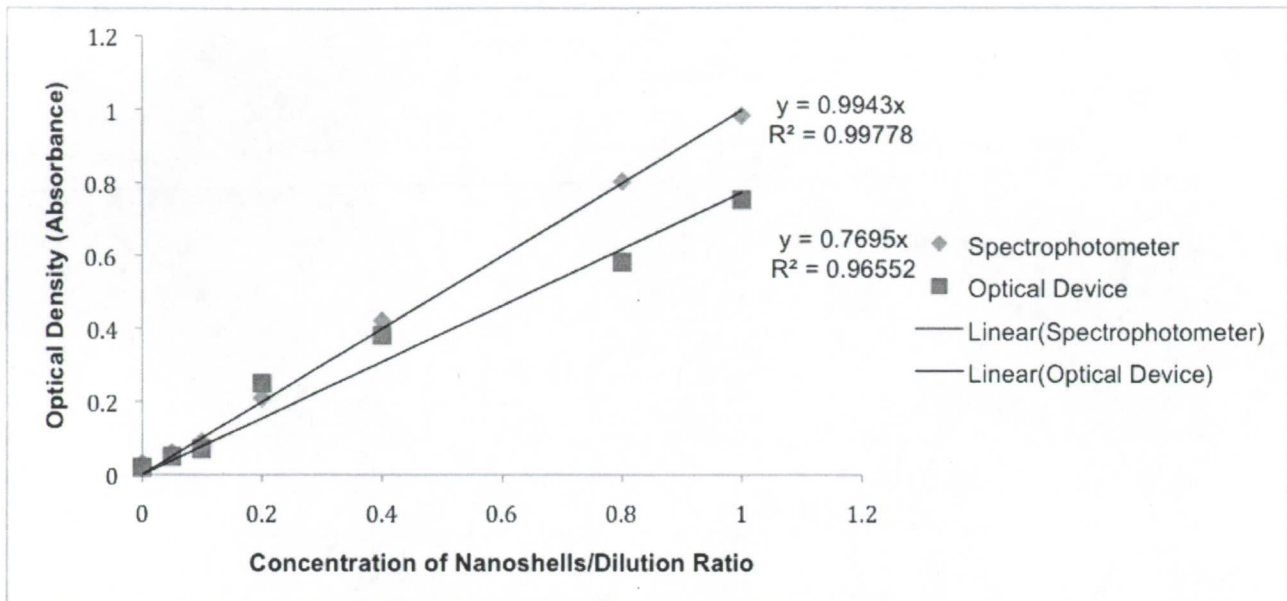


**Figure 15.** Nanoshell spectrum in a salt solution. The limited variability shows stability in a salt solution, e.g. urine.

## Spectrophotometer

### *Functionality test*

A linear trend is expected between measured absorbance levels and sample concentrations when the device is tested. Additionally, the device should produce corrected values within 10% of a laboratory-grade spectrophotometer. To perform this test, a series of diluted nanoshell solutions will be made that is the same as previous experiments (see verification and characterization of nanoshell function). These specimens are then placed in a cuvette between the light source and photodiode. While measurements are performed, all environmental variables will be kept constant, including room lighting, position of device and distance of cuvette from light source. From the voltage values collected, the absorbance values can be calculated, plotted against the known specimen concentrations and then linearly fitted to obtain a plot similar to figure 16.



**Figure 16.** Sample plot of absorbance vs. concentration of diluted sample for determining the quality of Team Taurus' optical device's functionality versus a commercial device.

These measurements are compared to those of the laboratory grade spectrophotometer (Fig. 16). The  $R^2$  of the linear fit is then calculated for variability comparisons. The measured absorbance values must be  $\pm 10\%$  of the laboratory grade spectrophotometer. If the  $R^2$  is greater than 0.95, or if Team Taurus' spectrophotometer produces absorbances that are greater than  $\pm 10\%$  of those measured by the laboratory spectrophotometer, the case will be re-designed to reduce the variation caused by sample and circuitry instability, as well as to reduce or eliminate outside light interference.

#### *Repeatability test*

An intrinsic issue with a constructed optical device used for measurement at a highly sensitive level is the concern with repeatability. Factors of the device such as reading time and signal noise will affect the repeatability of measurements of the same sample. Under the design criteria, the device must have a repeatability variation under 5% when the same sampled is measured multiple times. To confirm the repeatability of the device, a stable specimen will be measured five times within one minute of each measurement in the breadboard configuration. If absorption measurements exceed  $\pm 5\%$ , the focus for the spectrophotometer will be on a case re-design to stabilize the system.

### **III.6 System Analysis**

#### **WBS and Gantt Chart**

A work breakdown structure was created to maximize the efficiency of the design process. It can be found in appendix C. It separates the distinct components of the device and lists the required steps to achieve the design objects and requirements. There are seven levels assigned to the processes such that tasks across the components can be developed



simultaneously at each level. Tasks with dependencies are indicated in subsequent levels of development. The Gantt chart was derived from the WBS (see appendix F). This chart provides a projected timeline for the project development based on task deliverables for each component over time. A separate version of the Gantt chart based on resources and deliverables over time was also created (see appendix G).

### **Pugh Matrices**

In order to quantifiably rank design options, Pugh matrices were created for each development decision (see appendix E). In these matrices, design criteria were assigned weights of relative importance to accurately reflect system requirements. The standardly used technology is assigned a rank of 3 for all criteria. Each other option is ranked on a scale of 1-5 relative to the standard technology with 5 indicating a significant improvement and 1 indicating a drastic regression. Then, each technology is given a weighted ranking and judged with technologies are worth developing. Several cases were analyzed to incorporate the positive aspects of each design idea to further improve the rank.

## **IV. Transitioning Critical Technologies**

Currently, measuring the loss in BMD over time for astronauts is performed by freezing collected samples in space and subsequently analyzing the samples upon return to Earth. This is done by measuring for a specific marker correlated with BMD loss in blood, sweat, or urine, and then comparing the change in the marker's levels over time [Leach, 1979]. With this methodology, the detailed time dynamics of bone loss in microgravity is unknown. Additionally, the extent of the bone loss for each astronaut is unknown until the post-flight physical. Therefore, the integration of this new system would provide valuable information useful for mitigating the detrimental effects of a microgravity environment as well as for scientists to better understand the bone remodeling process under these conditions.

Four fundamentally different non-invasive approaches to measuring bone density loss in space were evaluated as possible implementable technologies—qualitative ultrasound (QUS), dual x-ray absorptiometry (DXA), body fluid biochemical marker analysis assays, and sweat patch measurements. The technologies were evaluated for durability, portability, and non-invasiveness as well as other assigned requirements using a Pugh matrix (appendix E). The urine analysis device was selected as the technology to integrate into the NASA space program.

The process inputs involved in the implementation of the Bone Remodeling Monitor include the spectrophotometer, a collection device for each crew member and the developed assay kit. It will be accompanied by a user's technical manual. It is recommended that a personal collection device for each of the astronauts on board be included to minimize contamination of the receptacle units. However, only one spectrophotometer and PDA will be necessary for all personnel. Further studies must be done before the specifics in the procedural frequency is determined. It is approximated that each astronaut should take a

measurement of their DPD concentration twice a week at the same time of day, to minimize the potential variation in the bone marker excretion. The collection device will be integratable into the waste collection system currently utilized by NASA. Following micturition, the astronaut must extract a sample of the urine in a syringe and combine it with a set volume of conjugated nanoshells. The resulting sample will be used in the spectrophotometer to determine the current concentration of the bone marker. This information will automatically be sent to NASA nutritionists and experts using the currently established web-based intranet system such that changes in the excretion of the bone marker can be tracked. The NASA experts can then alter the exercise and supplement regime as necessary. This procedure will be detailed in a user's technical manual. The associated risks to the implementation of the device into the space program are discussed in section X of this document.

## V. Integration of Systems Engineering Efforts

### V.1 Process Schedule

The overview of the four cycle design process is shown in figure 17. It involves an iterative process of research, design, testing, risk assessment and refinement to ensure that hazards and risks are mitigated in the final implementation of the system. Due to the non-invasive nature of the system, it is estimated the system could be ready for integration after the completion of two fiscal years.

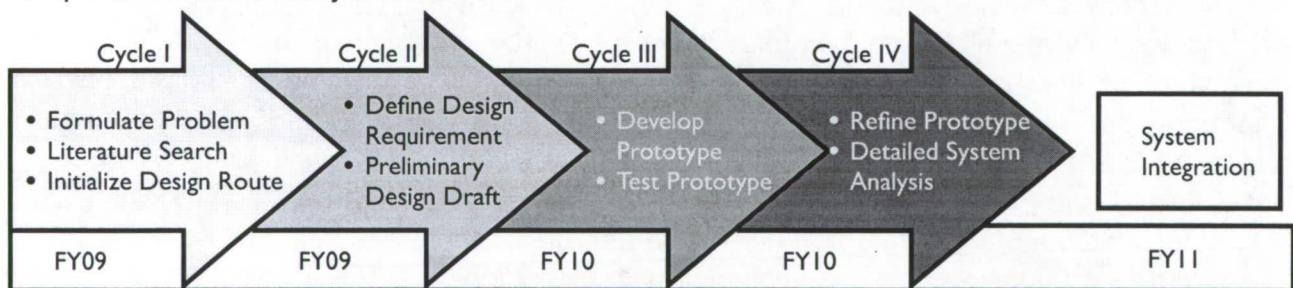


Figure 17. Overview of the process schedule.

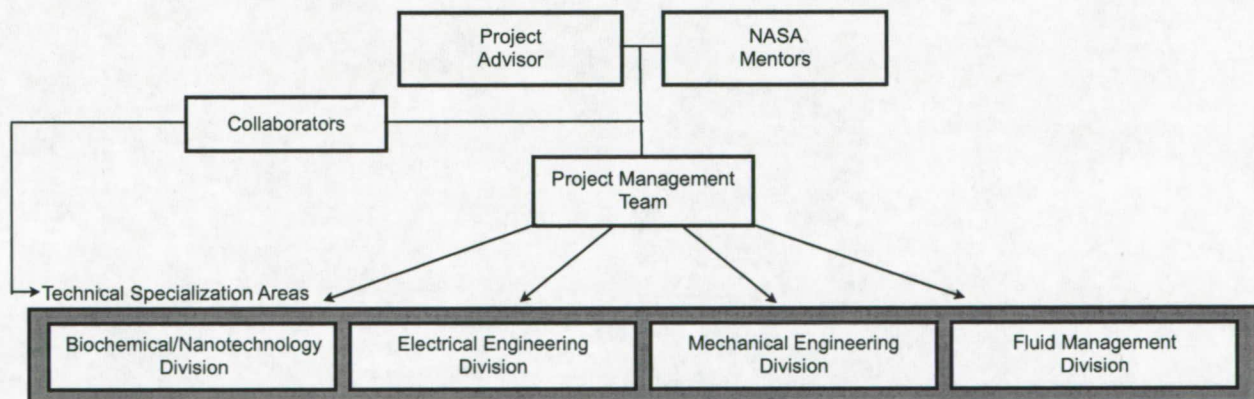
### V.2 Team Organization

The project is advised by Dr. Maria Oden, a member of the Bioengineering faculty at Rice University. Mentors from the NASA Johnson Space Center include Dr. Ruttley and Dr. Tomko. The team has also sought the advice of experts with specialized expertise in the fields of bone physiology in microgravity, electrical engineering, nanotechnology and fluid management. A list of the project collaborators is included in the appendix J. Figure 18 summarizes the team organizational setup. The internal team overseeing the planning and design of the system consists of five group members with the following responsibilities:

- **Charlie Foucar**, *Team Leader*

- Serve as the external liaison
- Maintain communications with mentors and other outside contacts
- **Shannon Moore, *Budgeting***
  - Responsible for budgeting and purchasing
  - Manage and maintain project documentation
- **Evan Williams, *System Supervisor***
  - Edit documents and maintain homogeneity among all Team Taurus documents (font, style, format, etc.)
  - Evaluate design process and progress. Provide feedback to the group when necessary.
  - Back-up documents
- **Bodin Hon, *Digital Media and Electronic Presentation Specialist***
  - Lead and supervise CAD modeling and Power Point presentation
  - Microsoft SharePoint administrator, a project organization and document management productivity tool
  - Manage Google account
- **Leslie Goldberg, *Purchasing***
  - Compile, write and submit weekly updates
  - Supervise deadlines
  - Maintain Gantt chart
  - Purchase materials

**Figure 18.** Team organizational flow chart.



## VI. Implementation Tasks

The second, and final, stage of the bone remodeling monitor involves the implementation of the device. This will require further testing and system analysis to validate the accuracy of the method and its effectiveness in managing treatment strategies. The device will first be tested against the design criteria with the testing methods (both outlined in this document). The software required for the operation and data collection of the device will be programmed in LabView Mobile Module and loaded onto the PDA. A user manual will be generated that includes basic software troubleshooting methods as well as methods to replace hardware using tools on board the space shuttle.

## VII. Cost Effectiveness Analysis

A quantifiable cost-effective analysis is difficult when the health of astronauts is involved. The estimated cost of implementation is low (approximately \$150,000 dollars per unit) compared to total mission budgets for manned space flight, which can range anywhere from \$500 million to \$170 billion (depending on the length and objective of the mission). Our device will ideally lead to fewer fractures and less irreparable damage to astronauts' skeletal systems. Although these effects would have a large impact on the probability of success for missions, it is difficult to assign a dollar value to these effects at this time.

### Cost Estimation and Budget Planning

Funds for this project come from CBEN and TSGC goal and level-based project funding. A total amount of \$1,000 in lump was received at the project's beginning. Funds from TSGC are awarded in the amount of \$125 following completion of each cycle, with an additional \$400 possible pending completion of three option areas. For semester 1, option areas were completed after cycle 2. Figure 19 illustrates the project's past spending profile as well as the projected income and expenditures through the project's completion after the second semester, indicated in orange.

As depicted in the graph, all expenditures fall within the range of the allocated budget. There is sufficient funding to support our project at all stages.

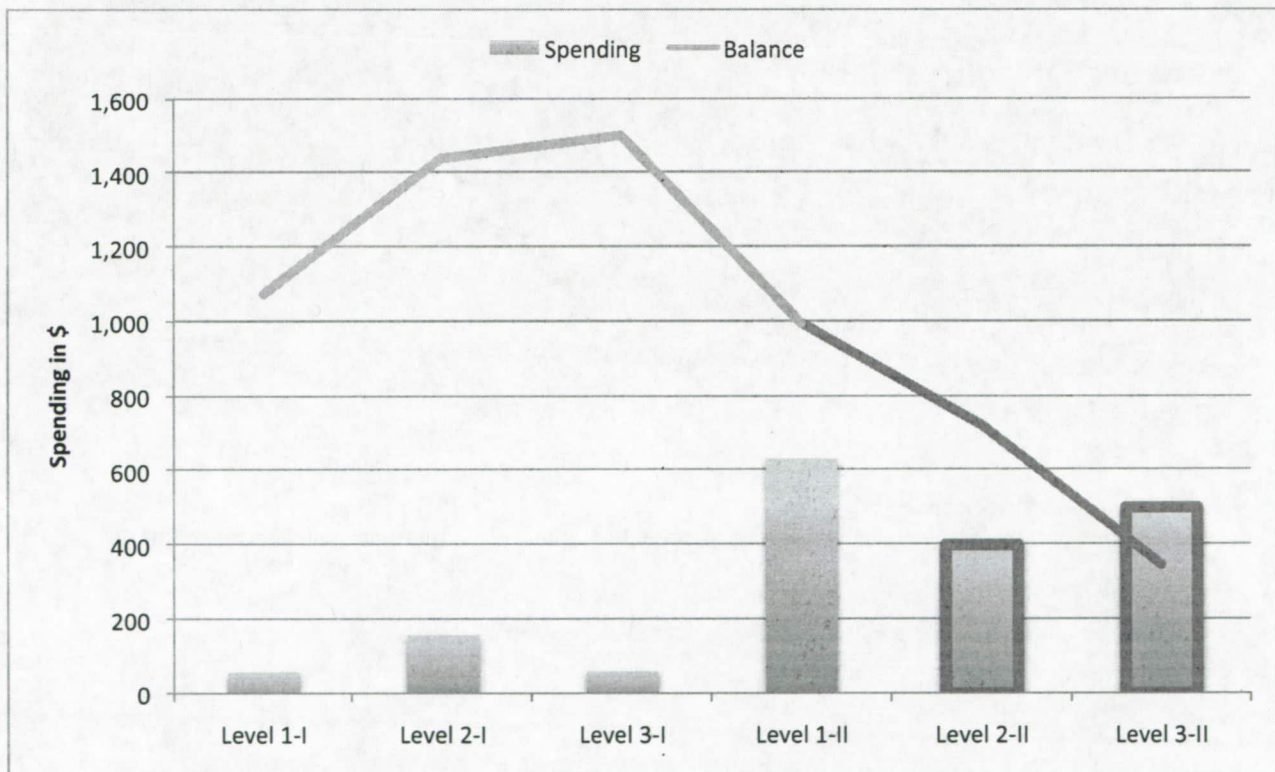
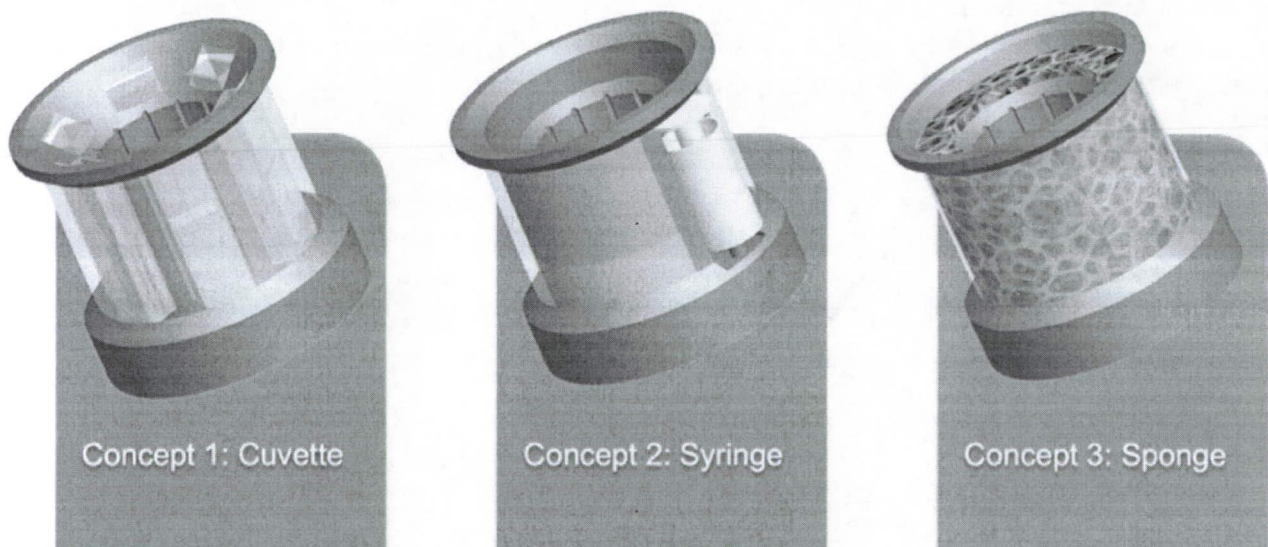


Figure 19. Cost engineering, budget for the system design.

## VIII. Design Configuration Control

### Collection Device: Configuration 1.0

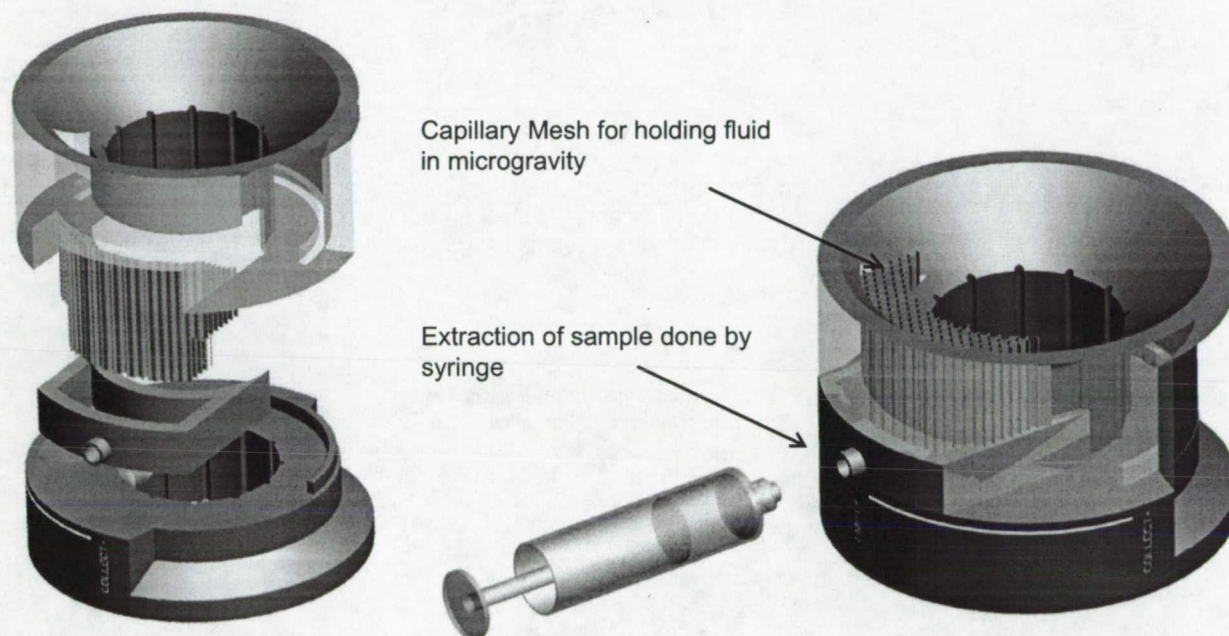
Collection device design began in September 2008, with three prototypes considered for the system (Fig. 20). The first proposed collection method (middle) takes advantage of airflow from the tube and redirects a fraction of the urine stream into a cuvette. A valve can be used to adjust the flow and close the system after the cuvette is full. The second proposed collection (middle) method employs a syringe to collect urine from the pressurized tube. This technique would allow astronauts to collect a specific volume of urine and deposit the sample directly in our device. The third proposed method of collection (right) would employ a sponge in the collection funnel of the WMS. After the sponge became saturated, it could be moved to a compression device that would collect the urine in a pressurized receptacle and deposit it into our device. The cuvette could then be sealed and carried to our device. Pugh matrices were created for the evaluation of each design (see appendix E), and as the system developed from theoretical implementation to practical construction, the system was refined.



**Figure 20.** Initial ideas (September 2008) for the collection chamber of the urine sample collection device.

## Collection Device: Configuration 2.0

The previous configuration lacked an element to be able to hold fluid in an open-container in microgravity. After further research, a similar device was found to successfully perform similar function. The Urine Receptacle Unit (URA) used for the Apollo mission was used to temporarily hold urine after astronauts micturate in an open-ended container before the urine is vented to space. This is achieved by using the surface tension properties of capillary bundles, in the form of perforated aluminum honeycomb (0.32cm pore size); additionally the honeycomb also acts as a static-phase air-liquid separator. Thus this configuration is focused on adding aluminum honeycomb into the device.



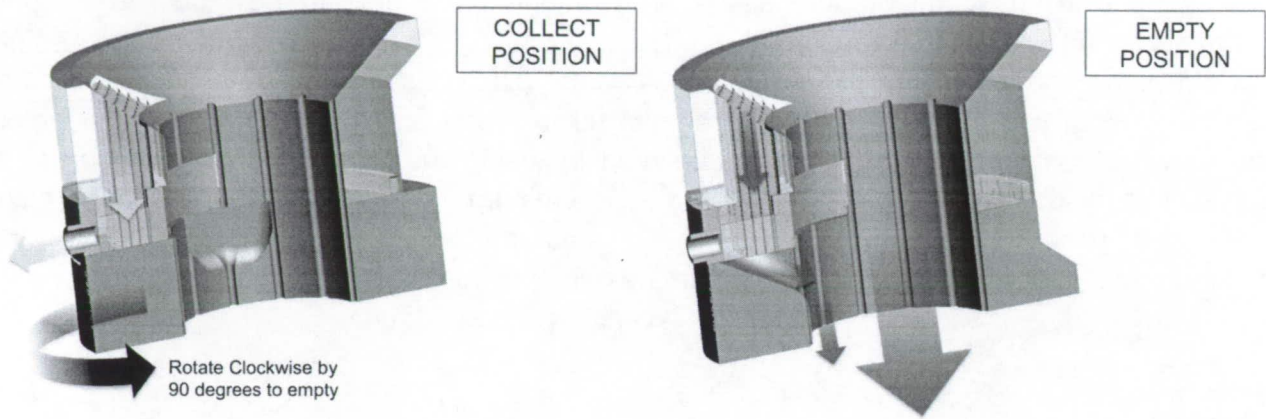
**Figure 21.** Collection device in configuration 2.0.

*Left:* Exploded view *Right:* Isometric view

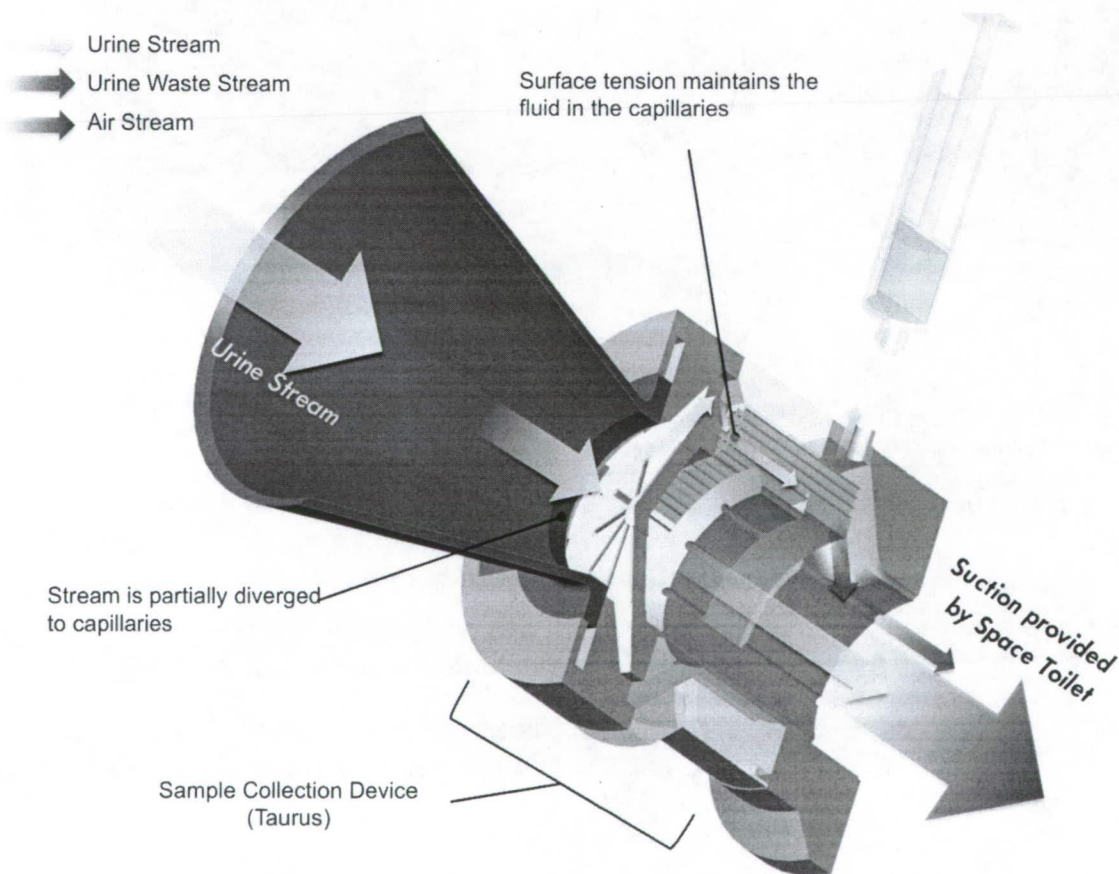
Further development concept of urine collection device that utilizes capillary bundles to hold fluid in microgravity. Subsequent extraction of the urine sample is performed by a syringe.

The sample will be temporarily stored inside the capillaries while flowing down the sides to collect in the collection chamber until after the entire space toilet system is shut down. Afterwards, a syringe will be inserted into a port to evacuate the sample in the chamber.

An additional feature add in configuration 2.0 is an integral capillary clearing mechanism where rotating of the base exposes the capillaries to the airflow from within the system to empty the capillaries.



**Figure 22.** Integrated honeycomb-clearing mechanism the collection device. Rotating of the device toggles the collection device between a cleaning position and a collection position. The cleaning position exposes the capillaries and the temporary collection chamber to the pressure provided by the space toilet and removes urine from the capillaries.

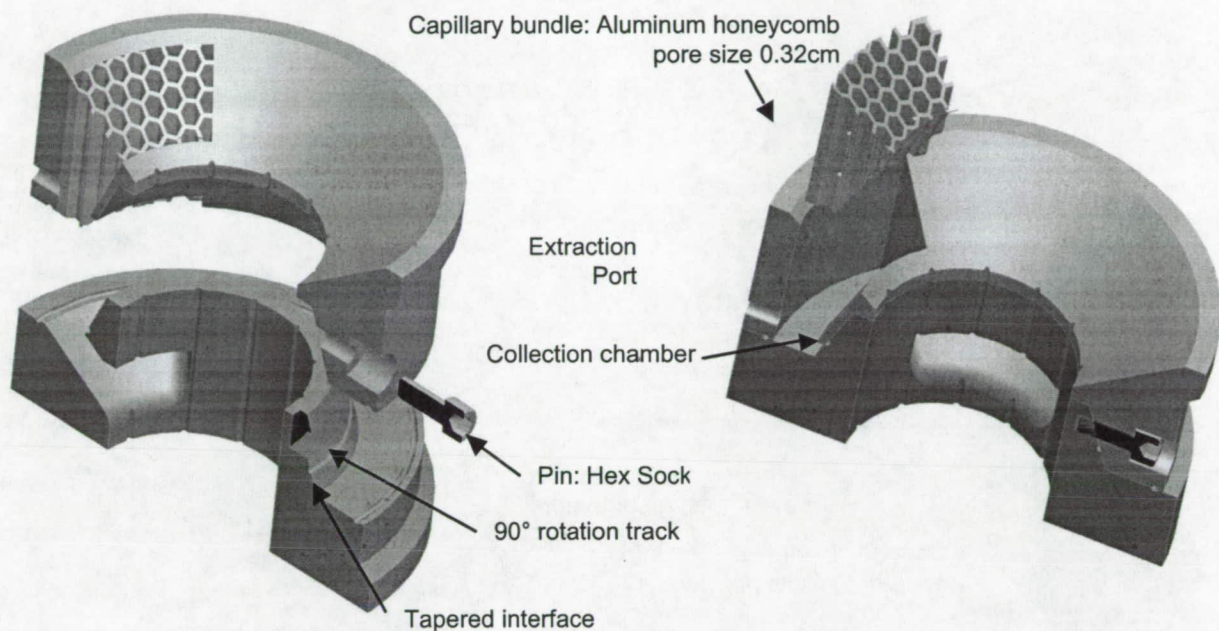


**Figure 23.** Cross section of urine sample collection device showing the pathways of urine and air.

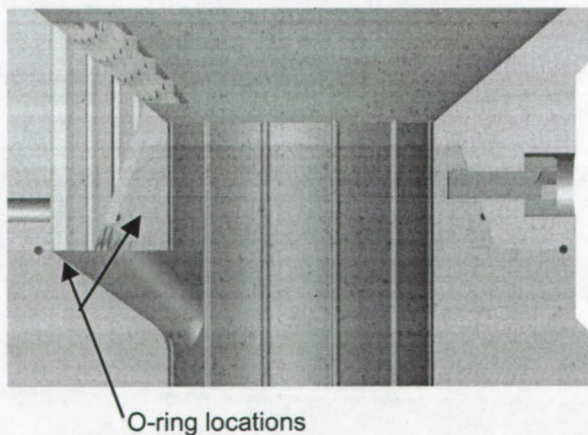


### Collection Device: Configuration 2.1

Development was focused on the locking mechanism which resulted in the addition of O-rings grooves, a position locking pin and a tapered cam-lock mechanism. The tapered interface and the locking pin are added to counteract any vertical movements during the 90° rotation. The pin is inserted after interfacing the 2 components; it also prevents over-rotation by following the rotation track (grey) so rotation is limited between COLLECT and EMPTY.



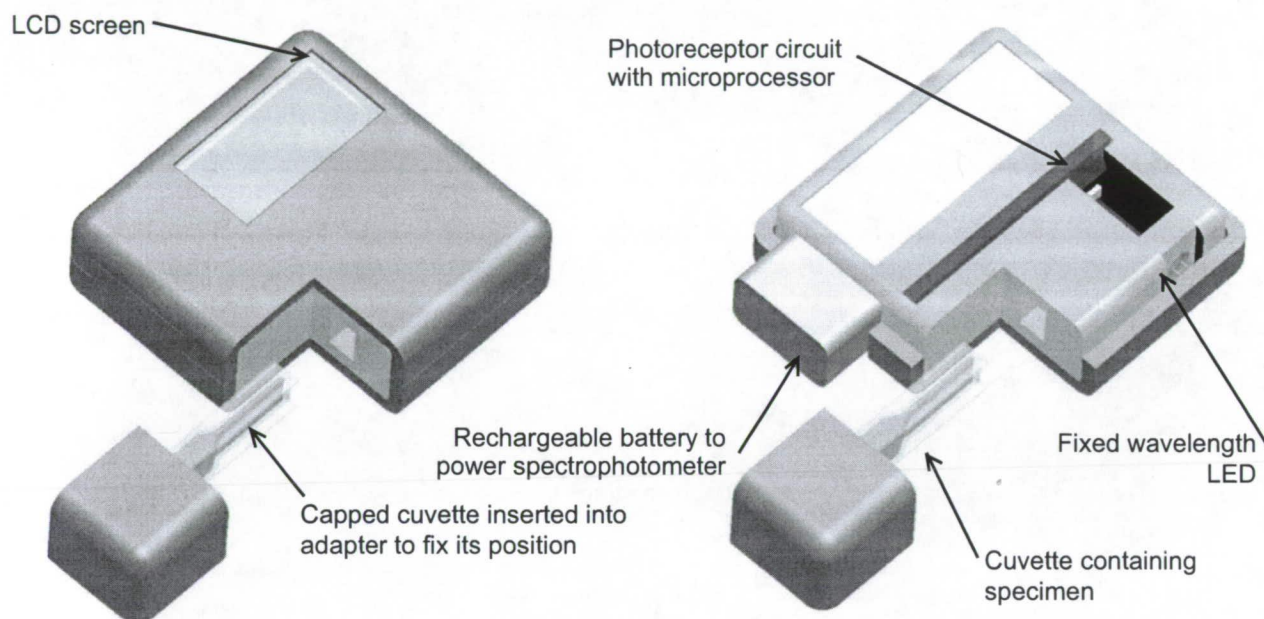
**Figure 24.** Cross section of partially exploded collection device showing the locking mechanism.



**Figure 25.** Cross section of partially exploded collection device in LOCKED position showing the capillaries bundle and collection chamber.

## Spectrophotometer: Configuration 1.0

Initial design on the method for quantifying the assay focused on what method to use: spectrophotometry, colorimetry, or a color-matching method similar to litmus paper. After these three designs were weighed against the design of the bone marker assay, spectrophotometry was chosen. For such a system, a fixed-wavelength LED tuned to the nanoshells, a photoreceptor, and a box preventing outside light yet allowing samples to be interchanged was required (Fig. 26).

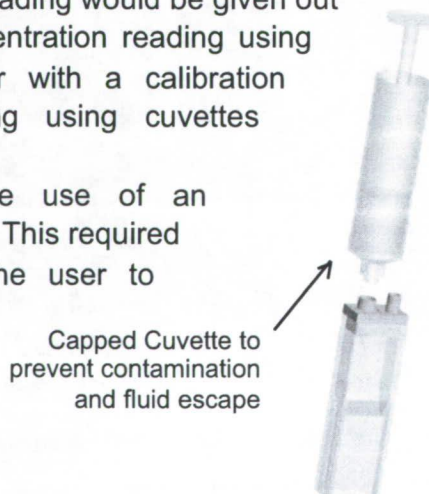


**Figure 26.** Isometric views of spectrophotometer in configuration 1 with cuvette and adapter shown.

The photodiode would detect the intensity of light after passing through the contents in the cuvette; a voltage reading would be given out and this could then be converted into a concentration reading using algorithms performed by the microprocessor with a calibration routine performed before a sample reading using cuvettes containing samples with known concentrations.

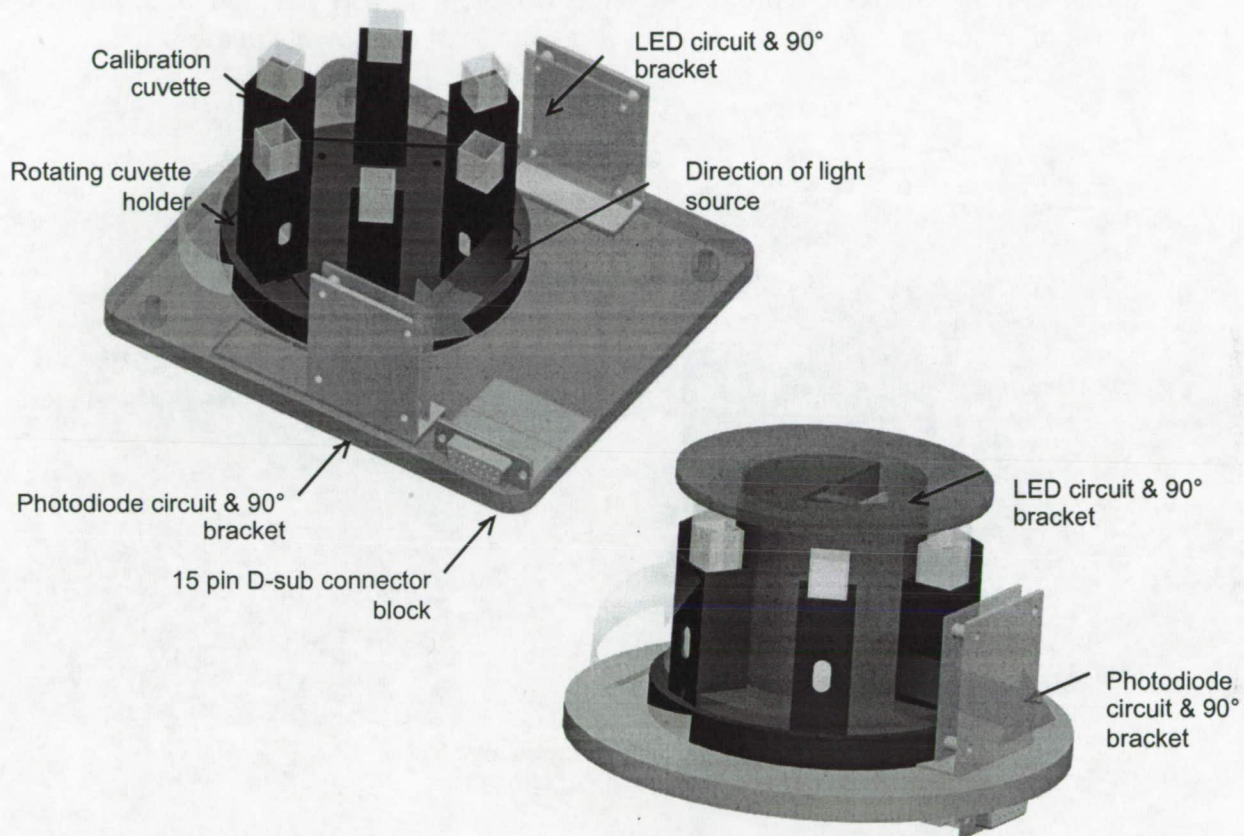
The initial design was based on the use of an independent microprocessor for data analyses. This required a power source, display and buttons for the user to interface with.

**Figure 27.** After extraction of sample from the collection device, urine is injected into cuvettes and then capped to contain fluid in microgravity.



## Spectrophotometer: Configuration 2.0

Development for the spectrophotometer was refocused on the inner mechanisms and layout, resulting in a complete redesign of the device. The main difference is the addition of a rotating multi-cuvette holder (carousel) to allow automatic system calibration to reduce the interaction time required by the astronauts. Furthermore additional components are added which includes: a 15-pin D connector block, a LED circuit board & a photodiode circuit board.

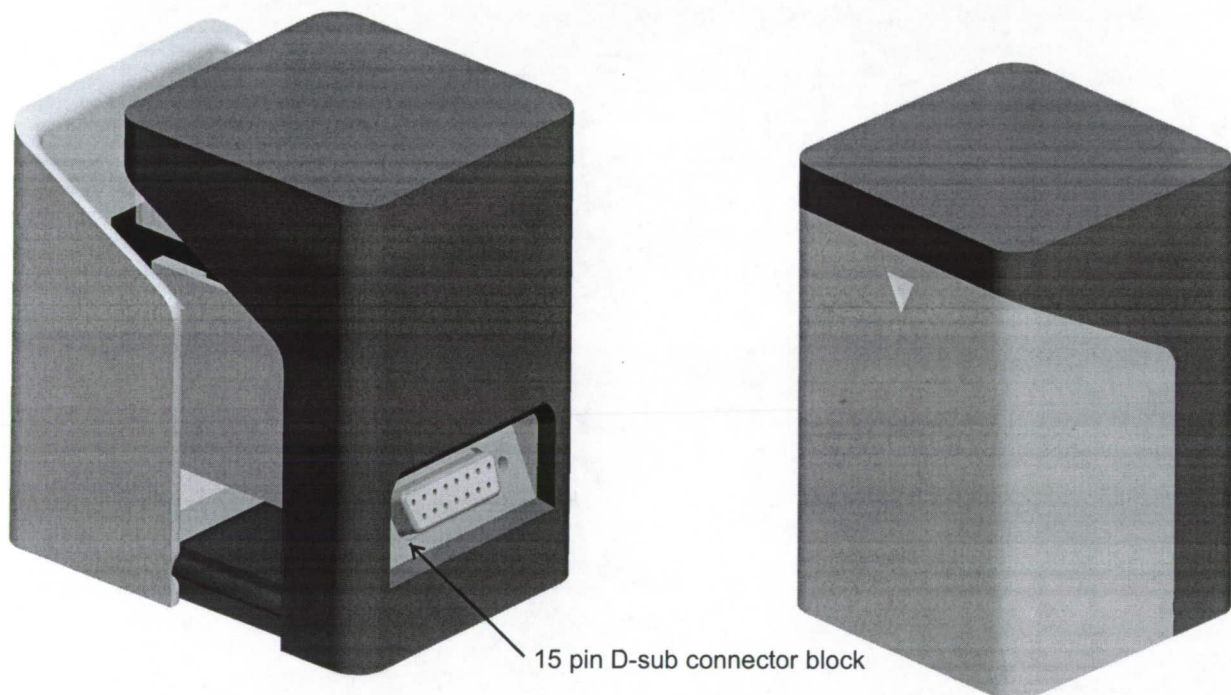


**Figure 28.** Two concepts of the inner mechanism of the spectrophotometer in configuration 2. Both includes the rotating carousel multi-cuvette holder with the left being a more condensed design.

However, the addition of the carousel resulted in the addition of around 10 more components, making this system overly complicated and hard to fix and maintain; thus it was decided to eliminate the carousel to reduce the complicity as well as the cost.

### Spectrophotometer: Configuration 3.0

Decision was made to focus on simplicity and to developing the most cost efficient solution, thus the carousel plan was abandoned in favor of a single cuvette holder design. Given the final decision to utilize a PDA and NI Labview Mobile as the primary user's interface with the spectrophotometer; a detailed bill of materials could be compiled which would include a 15 pin D-sub female connection to connect the spectrophotometer with the PDA through a cable. In trade with this additional component, the microprocessor, power source and display screen can be eliminated from the spectrophotometer, in addition this would also reduce the risk of exposing critical electrical components to possibly wet cuvettes.



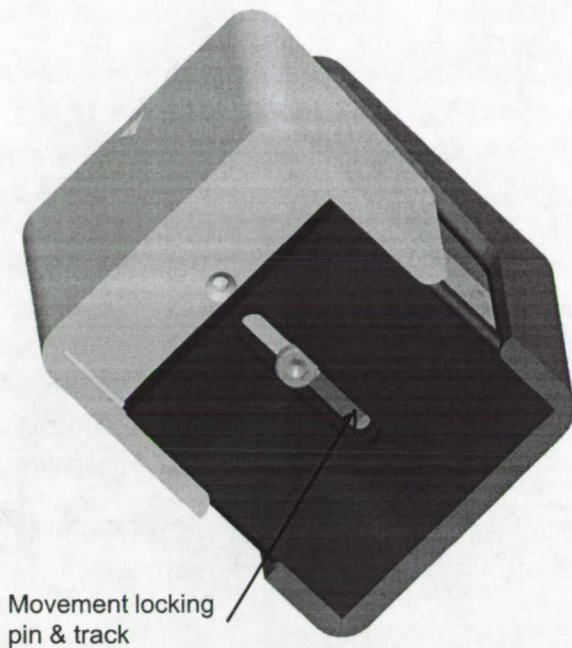
**Figure 29.** Front & Back Isometric view of the spectrophotometer. *Left:* The device is shown in its open position, which features a sliding mechanism. *Right:* The device is shown in its closed position with a 'cuvette placement orientation' arrow painted in white.

#### *Sliding Mechanism*

The spectrophotometer features a sliding mechanism as a means of opening the door to allow access to the inner compartment. The sliding mechanism consists of a groove and a pin to lock its travel.

#### *Connection Port*

The device features a 15pin D-sub female connection oriented 25° upwards to allow the data cable to be linked to the top of the PDA.



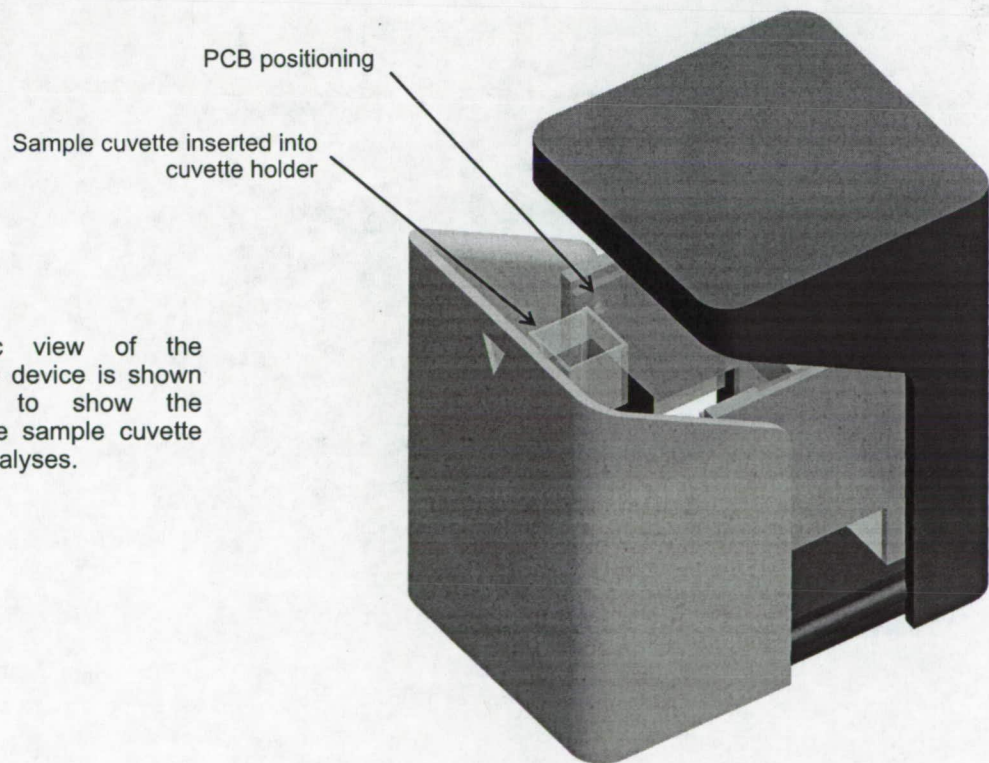
**Figure 30.** Bottom isometric view of the spectrophotometer. The device is shown slightly opened so that the movement track and pin can be seen.

*Cuvette Holder*

A standard commercial cuvette holder is integrated with the device which includes the correct positioning for a standard 1mL cuvette.

*Printed Circuit Boards*

PCB for the LED circuit and Photodiode circuit is and secured on both sides of the cuvette to to for consistent spectral measurements.



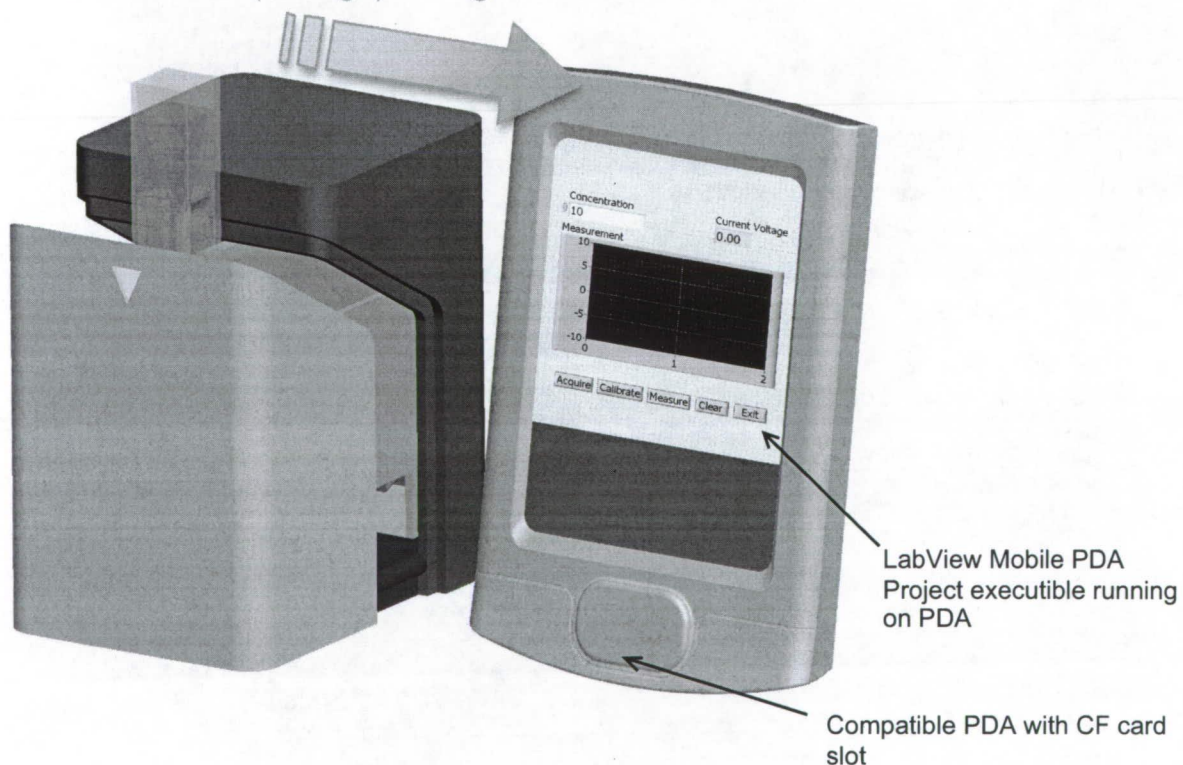
**Figure 31.** Isometric view of the spectrophotometer. The device is shown as slightly opened to show the compartment where the sample cuvette would be inserted for analyses.

## PDA Interface

The user-interface of the device utilizes a PDA with National Instrument (NI) Labview Mobile DAQmx Base installed. PDA running the platform Pocket PC 2003, Mobile 5 or 6 are compatible as long as they have a Compact Flash (CF) slot; this is necessary as the NI DAQ (data acquisition) card comes in the form of a CF card. Connecting the device through the 15pin D-sub connection to the PDA by the means of a cable provides it with 3.3V, which is sufficient to power the LED and photodiode circuits in connected in parallel. The advantage of using the PDA instead of an independent microprocessor is that more complicated functions can be programmed to be displayed on the high-resolution screen. The touch screen also allows a more interactive solution to perform the acquisition. Furthermore, the PDA is already an integral instrument used onboard the ISS and NASA's other vehicle systems, thus the program could be easily installed into another PDA with the DAQ card to start data acquisition.

However, the cost is much greater for this option as the NI CF-DAQ card CF-6004 and cable cost around \$800USD, while a PDA costs around \$200. A microprocessor and development board would cost only around \$200.

Data Transfer (Voltage) through NI cable



**Figure 32.** PDA interface with spectrophotometer.

## IX. Tradeoff Assessment

### **Pugh Matrices**

Throughout the design process critical decisions are made at each stage using Pugh analyses to make decision in concept exploration and development in areas such as feasibility, affordability, alternative system configurations and component/part designs.

Pugh matrices were created for each development decision (see appendix E). In these matrices, design criteria were assigned weights of relative importance to accurately reflect system requirements. The standardly used technology is assigned a rank of 3 for all criteria.

Each other option is ranked on a scale of 1-5 relative to the standard technology with 5 indicating a significant improvement and 1 indicating a drastic regression. Then, each technology is given a weighted ranking and judged with technologies are worth developing. Several cases were analyzed to incorporate the positive aspects of each design idea to further improve the rank.

### **Monitoring Technique Selection: Assay-based**

The initial trade report is to decide whether a imaging-based or assay-based technique is the most feasible technique to analyze bone mass density loss in a real time manner. The critical tradeoff is deciding between the power-consumption and weight of the imaging-based technique such as a bulky DEXA (X-ray imaging device) and the biological characteristic of an assay-base technique. Since this system is intended for a long duration mission abroad the CEV; size, weight and power consumption are the most heavily weighted criteria. The assay-based approach based on the criteria mentioned beforehand as well as it is not invasive.

### **Sampled Fluid Selection: Urine**

Sweat, urine, blood, and saliva were considered as potential candidates for our device. The favorable and unfavorable criteria were evaluated for each of the different options in a Pugh matrix in order to narrow down the selection. Urine was selected for use in the final design due to its ease, and non-invasive method of collection as well as the presence of a multiple markers that can be used to track the bone remodeling process.

### **Bone marker selection: deoxypyridinoline (D-Pyr)**

Bone remodeling markers present in urine were evaluated for use in the biochemical assay to determine bone loss. Bone resorption markers were chosen over bone formation markers due to their quick response time to intervention. using the Pugh matrix, the most stable, unique urinary bone marker was selected out of the list.

### **Quantification Method: Spectrophotometry**

Quantification methods such as spectrophotometry and fluorescence spectroscopy relate electromagnetic intensity to wavelength. Specifically, a spectrophotometer can quantify scattered light intensity, absorption and fluorescence by measuring light from a source, while fluorescence spectrophotometry measures the intensity of fluorescence from a sample after excitation [Braun, 2008].

## X. Risk Analysis

Following the device design, detailed risk assessment was done in order to minimize all risks associated with the system. These include risks that jeopardize the health of the astronauts, the success of the mission, and program costs. The technical risks associated with each component of the device were imagined and assigned an associated severity and consequence. Risk level was decided using a 5x5 risk assessment matrix and displayed in figure 32. The non-invasive interface minimizes immediate safety risks to the user. Therefore, there will be few, if any, health risks. However, secondary effects arising from the prescribed treatment modifications based on information received from the diagnostic tool pose minimal risk. Astronauts could inadvertently be harmed by any large errors in the device because of the decreased efficacy of bone loss treatments. For example, residual bone marker molecules left in an improperly cleaned system could lead NASA to prescribe too little or too much of a dose than is actually required. While brainstorming possible engineering failures, the design team concluded that most risks could be decreased to an acceptable level, so long as methods to ensure sample purity and device cleanliness were incorporated into the design. For further precision and accuracy before implementation, the device will be tested against other robust spectrophotometers which are standardized for laboratory use on Earth. Other risk factors, inherent to all devices with their own power sources, have been considered. These include voltages and currents that could, under the wrong conditions, light fires, produce smoke, or overheat. Risks of our device incurring these are negligible due to the low power requirements of this device.

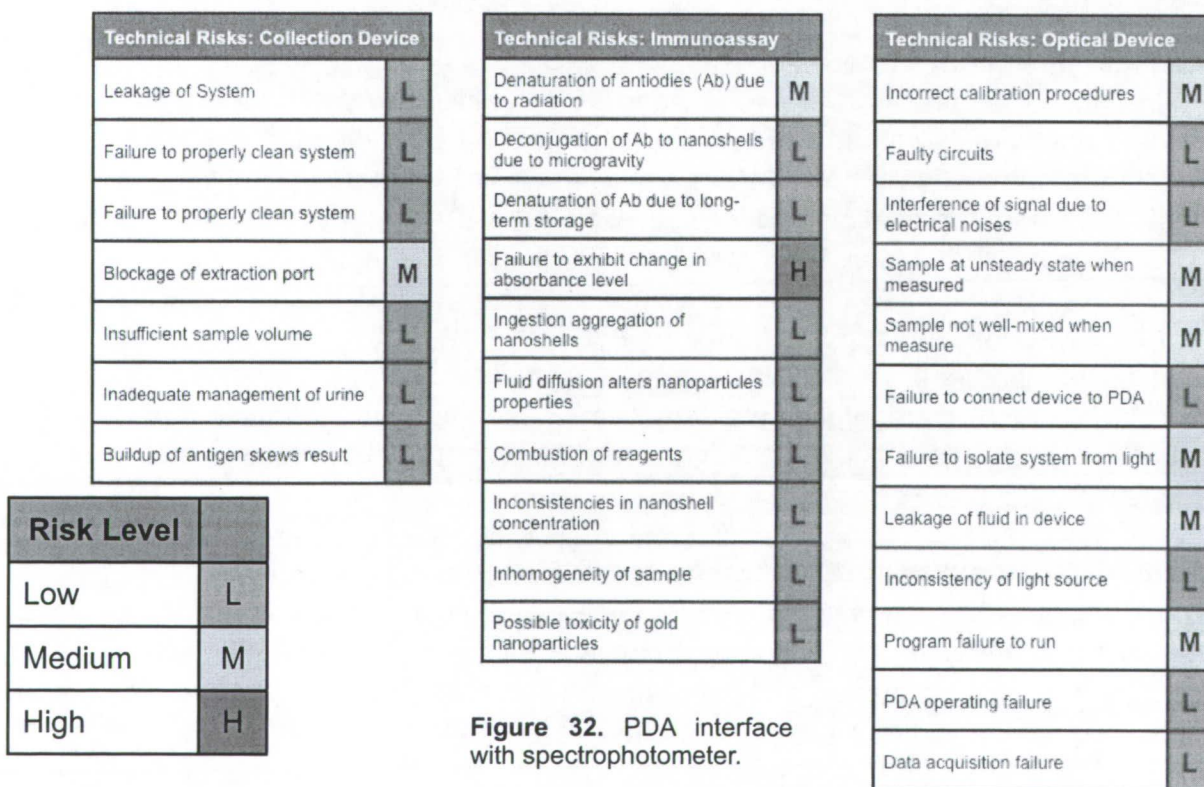


Figure 32. PDA interface with spectrophotometer.



## X. Conclusions

Over the course of the next few months, Team Taurus plans to further test and improve the collection device, portable spectrophotometer, and nanoshell assay. Possible improvements, such as a calibration carousel that would allow a user to load multiple samples for automatic calibration curve have been considered. More importantly, Team Taurus has outlined a series of functional experiments that will allow evaluation and improvements on the accuracy and precision of the device until it is ready for field testing.

Nanoshells have already been successfully synthesized for this device, with plans in action to further test the nanoshells to maximize their efficacy. Subsequently, the conjugated nanoshells are to be imaged using a scanning electron microscope to confirm both successful antibody conjugation and adequate PEG coating of the nanoshell. The decrease in absorption upon nanoshell agglomeration will be additionally verified by testing a solution of nanoshells on a laboratory-grade commercial spectrophotometer.

Lastly, a finalized urine collection device will be built using aluminum that will integrate with the space toilet found in NASA vehicles. This device will utilize the capillary action in capillary meshes to the control fluids in microgravity. The successful integration of these three components is the end goal for the project.

Currently there is an initial prototype of the bone remodeling monitor. Custom nanoshells have been synthesized, a functioning, preliminary portable spectrophotometer has been built, as has a plastic prototype for the collection device. During missions involving extended periods of space travel, NASA will be able to use a device like this device to monitor the efficacy of their proposed bone density loss treatments in real time. Using this data, mission control will be able to modify the treatment regiments to maximize their effectiveness. Team Taurus hopes that this device will help make long-term manned space travel more feasible in the future.

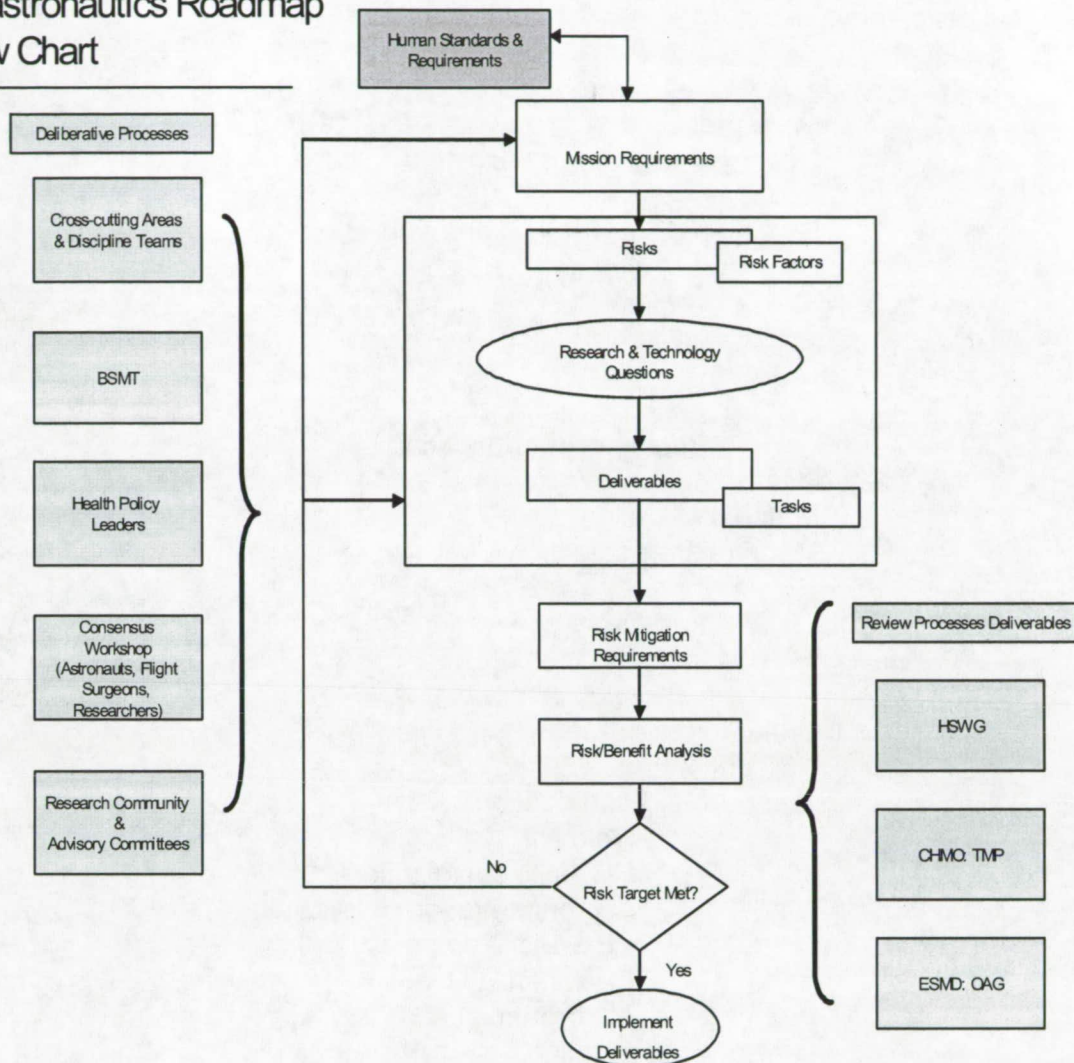
## XI. Appendices

### A. List of Acronyms

Ab	Antibody
BMD	Bone Mineral Density
CAD	Computer Aided Design
CBEN	Center for Biological and Environmental Nanotechnology
CEV	Crew Exploration Vehicle
CF	Compact Flash
CFD	Computational Fluid Dynamics
DAQ	Data Acquisition
DPD/D-pyr	Deoxy pyridinoline
DXA	Dual X-ray Absorptiometry
ELISA	Enzyme-Linked Immunosorbant Assay
ESMD	Exploration System Mission Directorate
FEA	Finite Element Analysis
FY	Fiscal Year
IgG	Immunoglobulin G
ISS	International Space Station
JSC	Johnson Space Center
LED	Light Emitting Diode
LCD	Liquid Crystal Display
NASA	National Aeronautics and Space Administration
NI	National Instruments
NS	Nanoshell
PBS	Phosphate Buffered Saline
PCB	Printed Circuit Board
PDA	Personal Digital Assistant
PEG	Polyethylene Glycol
PEG-Bis-A	Polyethylene Glycol
PEG-SH	Polyethylene Glycol Thiol
PERT	Program Evaluation Review Technique
TSGC	Texas Space Grant Consortium
QUS	Qualitative Ultrasound
RAID	Redundant Array of Inexpensive Disks
URU	Urine Receptacle Unit
VI	Virtual Instrument
WBS	Work Breakdown Structure
WCS	Waste Containment System
WMS	Waste Management System

## B. Bioastronautics Roadmap Flow Chart

### Bioastronautics Roadmap Flow Chart



<http://bioastroroadmap.nasa.gov/User/processes.jsp>

**C. WBS**

Handheld device for measuring bone mineral density loss in space

## ➔ Fluid collection device

- Collection device design
  - Integration with existing WMS
  - Placement within system
  - Design of locking mechanisms
- Function of device
  - Selection of fluid collection method
  - Selection of cleaning protocol
  - Fluid extraction
- Collection device prototype
  - 3D rapid prototype
  - CAD sketch-ups
    - Dimension determination
  - Casted plastic prototype
    - Material selection
    - Manufacturer selection

## ➔ Assay

- Selection of bone marker (D-pyr)
  - Determination of bodily fluid
- Assay type selection (nanoshell immunoassay)
  - Analyte concentration range determination
    - NS concentration
      - Ab/NS conjugation
        - Gold NS synthesis
        - PEG-SH optimization
        - Ab concentration optimization
        - PEG-Bis-A optimization
        - PBS stability test
        - Absorbance decrease experiment
  - Analyte concentration test
  - Validation with spectrophotometer

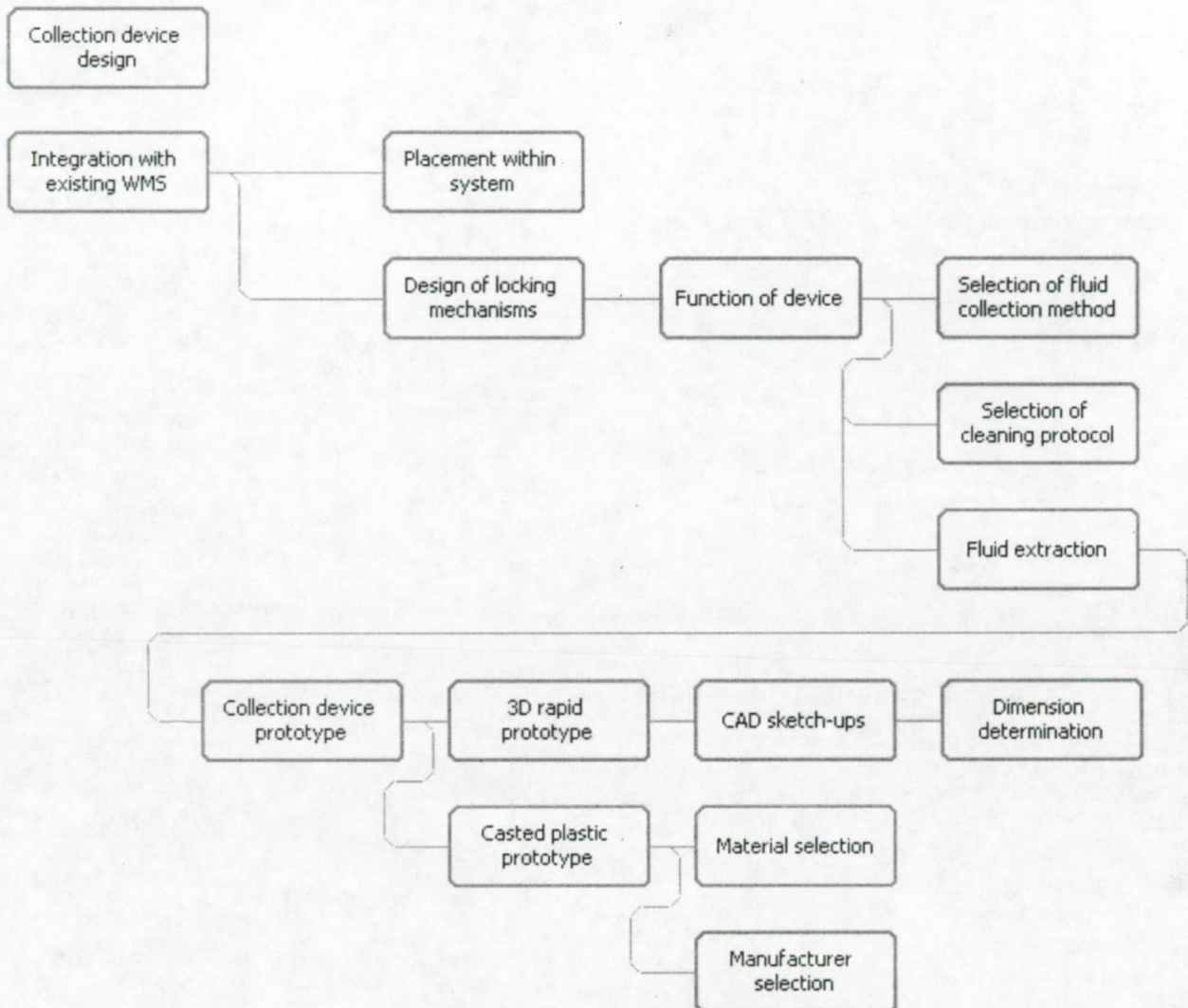
## ➔ Detection Method/Spectrophotometer design

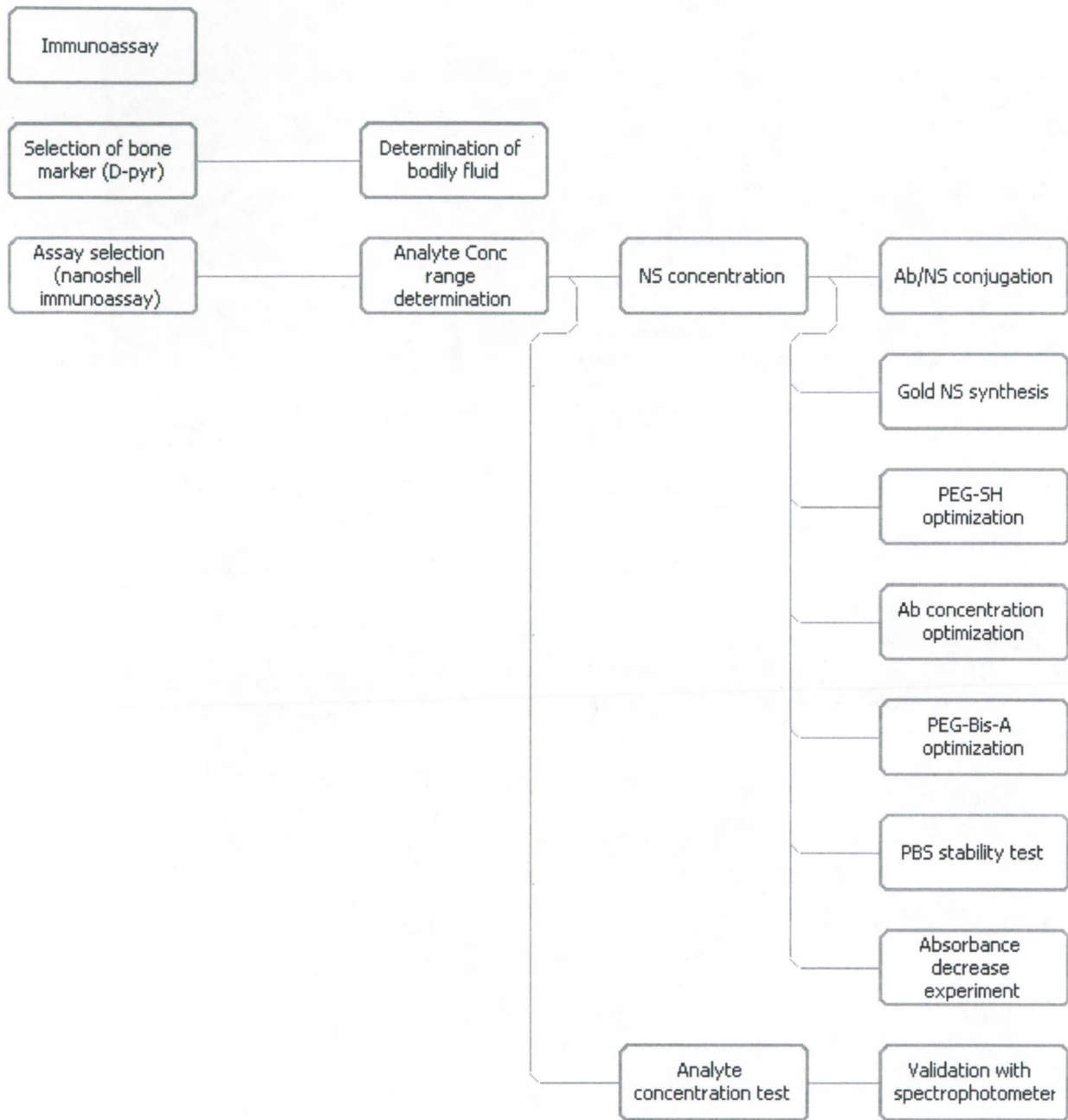
- Spectrophotometer Design
  - Casing
    - 3D prototype
      - Circuitry encasing
      - Locking and sliding
      - Component securement
      - Testing, analysis and redesign
  - Circuitry
    - Component (LED and photodiode) selection
      - Nanoshell peak absorbance wavelength
    - Signal amplification and processing
  - PDA Integration
    - PDA selection
- Device Calibration

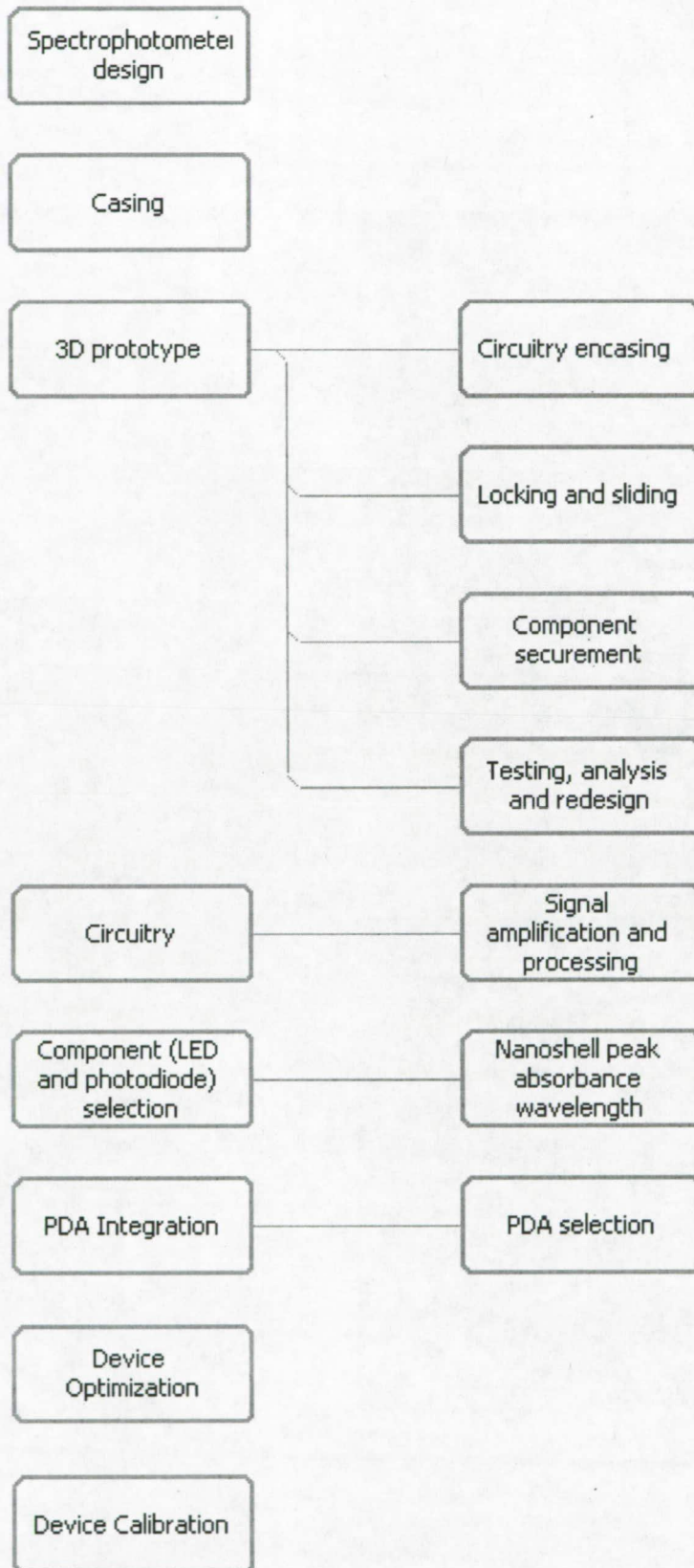
**Color Legend**

- Level 1
- Level 2
- Level 3
- Level 4
- Level 5
- Level 6
- Level 7

### D. Flowcharts - Detailed Component Operations







## E. Pugh Matrices

### Specimen of Analysis

Evaluation Criteria	Weight	Urine	Sweat	Serum	Saliva
Non-Invasiveness	25%	5	5	3	4
Ease of collection	20%	5	4	3	4
Ease of analysis	15%	3	2	3	2
Presence of bone markers	15%	3	2	3	2
Consistency	10%	3	1	3	3
Storability	5%	5	3	3	3
Weighted Score		3.7	2.9	2.7	2.85
Rank		1	2	4	3
Continue		Yes	No	No	No

### Extraction Method - Collection Device

Evaluation Criteria	Weight	Syringe	Cuvette	Sponge
Ease of collection	20%	3	3	3
Ease of analysis	20%	3	3	1
Precision	15%	4	3	4
Reusable	15%	4	3	1
Portable	15%	4	3	2
Durable	5%	3	3	2
Weighted Score		3.15	2.7	1.95
Rank		1	2	3
Continue		Yes	Yes	Yes



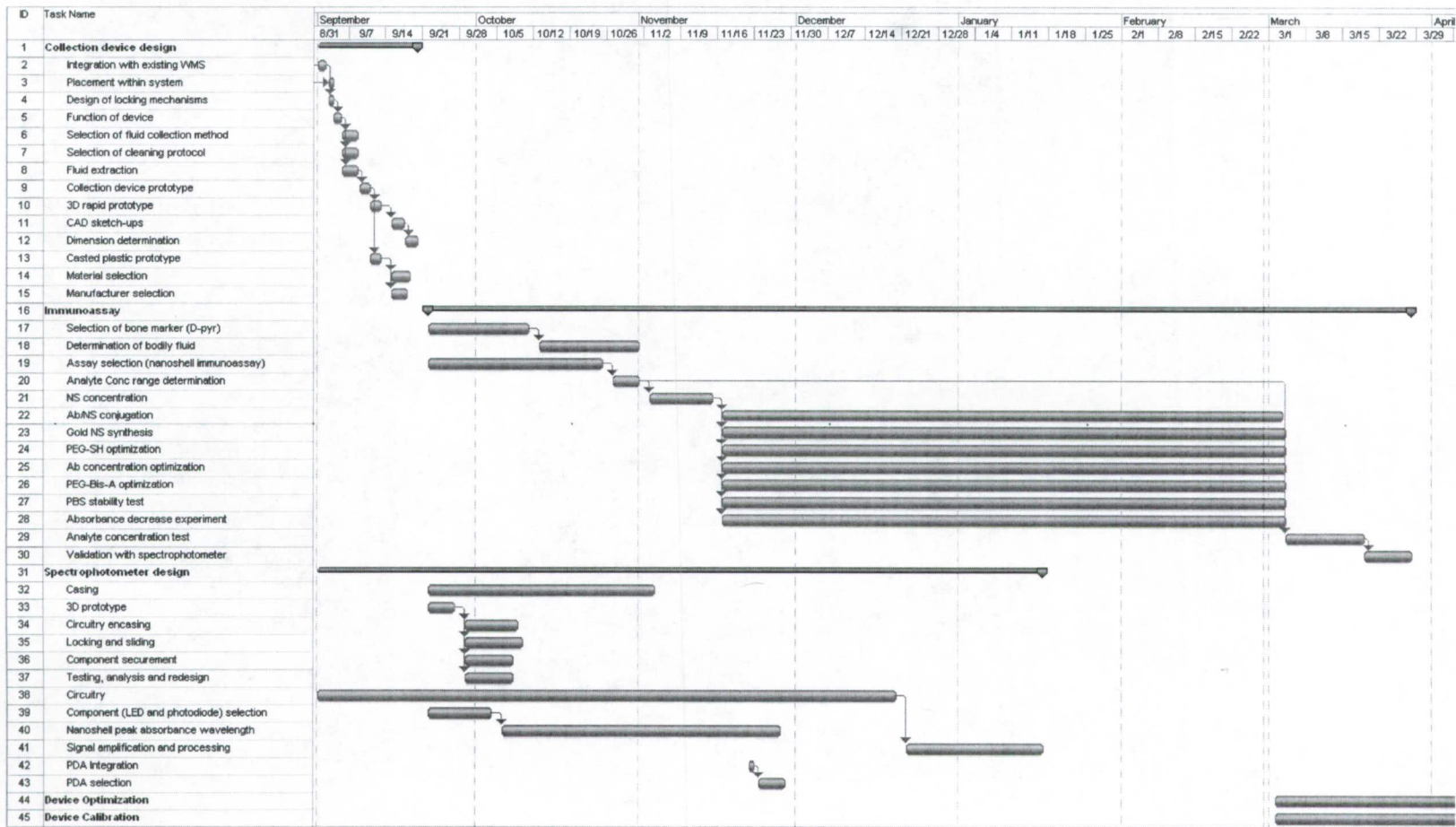
## Assay Technique

Evaluation Criteria	Weight	ELISA	Qdot	Nanoshell
Microgravity viability	40%	3	4	4
Research focus	30%	3	1	2
Availability of reagents	20%	3	1	4
Adaptability	10%	23	5	4
Weighted Score		3	2.6	3.4
Rank		2	3	1
Continue		No	No	Yes

## Assay Quantification

Evaluation Criteria	Weight	Spectrophotometry	Colorimetry	Color chart
Accuracy	25%	5	4	3
Precision	25%	5	4	3
Ease of implementation	20%	2	2	3
Feasibility	10%	4	4	3
Robustness	10%	3	3	3
Energy requirement	10%	2	2	3
Weighted Score		3.8	2.6	3
Rank		1	3	3
Continue		Yes	No	No

F. Gantt Charts



Cycles 1 & 2: Based on resources and time.

TEAM TAURUS Cycles I & II													LEGEND: Planned In Progress Completed Cycle I Cycle II					
Week #	1	2	3	4	5	6	7	8	9	10	11	12	13	LOGGED HOURS BY ACTIVITY				
Dates (Mon-Sun)	9/8-9/14	9/15-9/21	9/22-9/28	9/29-10/5	10/6-10/12	10/13-10/19	10/20-10/26	10/27-11/2	11/3-11/9	11/10-11/16	11/17-11/23	11/24-11/30	12/1-12/7	Charlie F.	Leslie G.	Badin H.	Shannon M.	Evan W.
ACTIVITY																		
PROJECT REQUIREMENTS	DUE DATE																	
<b>General Activities</b>																		
Team Contract	2													2				
Team Contract maintenance	2													1				
Update timetable	3													1				
Weekly reports	1.5													1.5				
Meetings with mentors/collaborators	1.5													1.5				
<b>Prepare Level I Requirements</b>	6-Oct																	
Define Project	3.5													1.4				
Background research	4													1.4				
Identify user needs/constraints on design	9													13				
Brainstorm Ideas	32													14				
Develop objectives and criteria	24													1.4				
Write and prepare Level I Report	2													1.4				
Design Context Review	15-Oct													1.4				
<b>Prepare Level II Requirements</b>	27-Oct													1.5				
create CAD drawings of ideas	31-Oct													24				
design patch	2													2				
Pugh Chart	2													1				
Assemble remaining Level II requirements	20													0.5				
Draft powerpoint	15													4				
Research and decide materials for prototype	12													4				
Order essential materials for prototype	26													7				
<b>Prepare Level III Requirements</b>	23-Nov													[4]				
Finalize design concept	25													17				
construct prototype	30													17				
test prototype	11													17				
<b>final technical report</b>	1-Dec													1				
Modify and update mission report	12													9				
create drawings and schematics	20													9				
analyze data from testing	25													9				
update powerpoint presentation	[40]													9				
practice oral presentation	20													12				
participate in Showcase	15													4				
Prepare Travel Grant	25													4				
<b>OPTION AREAS</b>																		
<b>Outreach (Option I)</b>	14-Nov																	
Planning - idea development	2													2				
Planning -prepare materials	3.5													2.5				
outreach event	18													4				
<b>Presentation to mentor (Option II)</b>	14-Nov																	
Prepare Presentation	10													6				
<b>Website (Option III)</b>	14-Nov																	
Design Website	1													7				
create individual pages	6													4				
Manage/update website	4													9.5				
<b>LOGGED HOURS BY WEEK</b>																		
Charlie Foucar	4	12	12	11	11	14	18	11	12	20	16							
Leslie Goldberg	4	12	12	11	11	14	18	11	12	20	16							
Badin Hon	4	12	12	11	11	14	18	11	12	20	16							
Shannon Moore	4	12	12	11	11	14	18	11	12	20	16							
Evan Williams	4	12	12	11	11	14	18	11	12	20	16							
<b>TOTAL</b>	20	60	60	55	55	70	90	55	60	100	80	0						

**TEAM TAURUS**  
Cycles III & IV

LEGEND: Planned In Progress Completed Cycle III Cycle IV

ACTIVITY	DUE DATE	Week #	14	15	16	17	18	19	20	21	22	23	24	25	LOGGED HOURS BY ACTIVITY					
		Dates (Mon-Sun)	1/5-1/11	1/12-1/18	1/19-1/25	1/26-2/1	2/2-2/8	2/9-2/15	2/16-2/22	2/23-3/1	3/2-3/8	3/9-4/15	4/16-4/22	4/23-4/29	Charlie F.	Leslie G.	Bod n H.	Shannon M.		
<b>PROJECT REQUIREMENTS</b>																				
<b>General Activities</b>																				
Update timetable							1		[1]		[1]		[1]				1			
Update website							1		[2]		[2]		[2]							
Weekly reports			1.5	1.5	1.5	1.5	1.5	[1.5]	[1.5]	[1.5]	[1.5]	[1.5]	[1.5]	[1.5]	[1.5]		2.5	5		7.5
Maintain budget report			1.5	1.5	1.5	1.5	1.5	[1.5]	[1.5]	[1.5]	[1.5]	[1.5]	[1.5]	[1.5]	[1.5]					
Meetings with mentors/collaborators					8	7	5		[1]	[1]							3	4	4	4
<b>Prepare Level III Requirements</b>																				
Finalize design concept	9-Feb		2														0.5	0.5	0.5	0.5
construct prototype																				
Collection Device						2	1				[20]									
Assay development				14		10	12	[30]	[30]								18	1	2	18
Spectrophotometer			8	1	8	12		[20]	[20]									9	9	
Assay Experimentation					5	4											4.5			4.5
test prototype						9											2	2	2	2
Parts list						2											1			
Design report						20											4	4	4	4
Previous cycle document revision			5			10											2	2	2	2
<b>Prepare Level IV Requirements</b>																				
Final Technical Report	9-May																			
Modify and update mid-term report	1-Apr							[15]	[15]	[15]	[15]	[15]	[15]	[15]						
Update drawings and schematics									[10]	[10]	[10]	[10]	[10]	[10]						
Analyze experimental data												[5]	[5]	[5]						
Update powerpoint presentation																				[20]
Update poster	25-Mar											[5]	[10]	[15]						[15]
User manual													[10]	[15]						[15]
Summary of conference presentation																				[2]
Final revision of previous documents								[10]	[10]		[10]	[10]		[10]						[10]
<b>LOGGED HOURS BY WEEK</b>																				
Charlie Foucar			4	7	2	7	16													
Leslie Goldberg			4	3	2	7	16													
Bod n Hon			4	3	2	7	16													
Shannon Moore			4	7	2	7	16													
Evan Williams			4	3	2	7	16													
<b>TOTAL</b>			20	23	10	35	80													

## G. Budget Plan

Team Taurus  
Development Cost Projection

PROJECT EXPENDITURES	Vendor	Part Number	Notes	Estimated Cost
Rabbit IgG	GE Healthcare Lifescience	NA934-100UL		\$65.00
Anti-rabbit IgG	Sigma-Aldrich	R2004-1MG		\$59.00
HEPES buffer	Sigma-Aldrich	H0887-20ML		\$15.90
Anti-Rabbit IgG	Sigma-Aldrich	R5506		\$106.00
IgG from rabbit serum	Sigma-Aldrich	I8140		\$19.50
ProE Software, student edition	ptc.com	Wildfire 4.0		\$129.99
NI Connector Cables	National Instruments	191067-0R5		\$29.00
NI Connector Block	National Instruments	779198-01		\$49.00
PDA	Online Used Vendor	HP Ipaq PDA Pocket PC Computer 2215		\$99.00
LED, PC Board	Radioshack			\$7.27
Aluminum materials for casing	Alcore			\$100.00
cuvettes, lids	Starna Cells			\$50.00
3D prototyping	Rice BIOE Dept.			\$355.00
Mechanical locks	Rice Machine Shop			\$50.00
Misc Laboratory Chemicals	Rice BIOE Dept.			\$150.00
Nanoshells	Nanopartz			\$400.00
Anti-dpyr	Sigma-Aldrich			\$500.00
<b>EXPENDITURES</b>				<b>\$2,184.66</b>
<b>EARNINGS</b>				
	Amount			
TSGC Design Competition Grant	\$1,275.00			
CBEN (Nanotechnology Grant)	\$1,000.00			
<b>EARNINGS</b>				<b>\$2,275.00</b>
<b>Balance</b>				<b>\$90.34</b>

The projected implementation costs figure estimates the cost of implementing one of our devices on a two year mission. Some of the costs, such as the costs of nanoshells, increase with the implementation of more units. However, other costs, like those for software, would only be paid once and would not increase with the implementation of more units.

Team Taurus  
Implementation Cost Projection

PROJECT EXPENDITURES	Vendor	Part Number	Notes	Estimated Cost
Bone Remodeling Monitor				\$800.00
Labview Software				\$4,500.00
Misc Parts for Repair				\$1,000.00
Collection Device				\$500.00
NI Connector Cables	National Instruments	191067-0R5		\$29.00
Reusable Cuvettes and lids	Starna Cells			\$1,000.00
Nanoshells w/ Conjugated Anti-Dpyr	Nanopartz			\$150,000.00
<b>EXPENDITURES</b>				<b>\$157,829.00</b>

## H. References

Akrout L., Padilla F., Kolta S. Feasibility of quantitative ultrasound measurement at femur. IEEE Ultrasounds Symposium: 1353-6, 2002.

Alexandre C, Caillot-Augusseau A., et al. Bone formation and resorption biological markers in cosmonauts during and after a 180-day space flight (Euromir 95). *Clinical Chemistry* 44: 578-85, 1998.

Braun, Robert D. Analysis (Physics and Chemistry). *Encyclopedia Britannica*. 2008.

Clunie, G., Keen, R. Osteoporosis. Oxford University Press. 2008.

Collet P., Uebelhart D., et al. Effects of 1- and 6-month spaceflight on bone mass and biochemistry in two humans. *Bone* Vol. 20, No. 6: 547-551, 1997.

Dassault Systèmes SolidWorks Corp. Solidworks. Vers. 2009. Computer software. 3D CAD Design Engineering Tools. 3 Dec. 2008. <<http://www.solidworks.com/sw/3d-cad-design-software.htm>>.

Delmas P.D., Eastell R., et al. The use of biochemical markers of bone turnover. *Osteoporosis Int Suppl*. 6: S2-17, 2000.

Engvall E., Perlman P. Enzyme-linked immunosorbent assay (ELISA). Quantitative assay of immunoglobulin G. *Immunochemistry* 8(9): 871-4, 1971.

Gonter, N., DEXA and bone density tests vs. bone density scans. *Osteoporosis Connection*. 2007.

Gross J., de Azevedo M., et al. Diabetic nephropathy: diagnosis, prevention, and treatment. *Diabetes Care* 28 (1): 164-76, 2005.

Hirsch, L., Halas, N., West, J. Whole-Blood immunoassay facilitated by gold-nanoshell-conjugate antibodies. *Methods of Molecular Biology* (303): 101-11, 2008.

Hirsch L., Gobin A., Lowery A., et al. Metal Nanoshells. *Annals of Biomedical Engineering* 34: 15-22, 2006.

Iwamoto J., Takeda T., Sato Y. Interventions to prevent bone loss in astronauts during space flight. *Keio J Med*. Vol. 52 No. 2: 55-9, 2005.

Jorgensen G.K. Waste management system. SP-368 biomedical results of Apollo Section VI Ch 2. Scientific and Technical Information Office, National Aeronautics and Space Administration, Washington D.C., 1975.

Leach C.S., Rambaut P.C. Aminoaciduria in weightlessness. *Acta Astronautica* Vol. 6: 1323-33, 1979.

LeBlanc A., V. Schneider. Countermeasures against space flight related bone loss. *Acta Astronautica* Vol. 27: 89-92, 1992.

LeBlanc, A., et al. Bone mineral and lean tissue loss after long duration space flight. *J Musculoskel Neuron Interact* 1: 157-60, 2000.

Leeming D.J., Alexandersen P., et al. An update on biomarkers of bone turnover and their utility in biomedical research and clinical practice. *Eur J Clin Pharmacol* 62: 781-92, 2006.

Mentor Graphics. FloEFD. Computer software. Fluid Simulation and CFD Software. 3 Dec. 2008 <<http://www.flomerics.com/index.php>>.

Medintz I., Uyeda T., et al. Quantum dot bioconjugates for imaging, labeling and sensing. *Nature Materials* 4: 435-46, 2005.

NASA Systems Engineering Handbook. NASA Headquarters, Washington, D.C.. NASA/SP-2007-6105 Rev1.

Oldenburg S.J., Averitt R.D., et al. Nanoengineering of optical resonances. *Chemical Physics Letters* 288: 243-7, 1998.

Prasad, K.M., et al. Basic aspects and applications of tristimulus colorimetry. Elsevier Science: 1187-206, 1996.

Robins S.P., Woitge H., et al. Direct, enzyme-linked immunoassay for urinary deoxypyridinoline as a specific marker for measuring bone resorption. *Journal of bone and mineral research*. Vol. 9: 1643-9, 1994.

Rosendahl, U., Dreyer, M.E. Design and performance of an experiment for the investigation of open capillary channel flows. *Exp. Fluids* 42: 683, 2007.

Seibel, M. Biochemical markers of bone turnover part II: clinical applications in the management of osteoporosis. *Clin Biochem Rev*. 27: 123-38, 2007.

Shapiro, Bone loss team strategic plan. J. NSBRI. 2003.

Smith S., M. Heer. Calcium and bone metabolism during space flight. *Nutrition* 18: 849– 852, 2002.

Smith S., et al. Collagen cross-link excretion during space flight and bed rest. *Journal of Clinical Endocrinology and Metabolism* 83: 3584-91, 1998.

Stewart A., Reid D.M. Precision of quantitative ultrasound: comparison of three commercial scanners. *Bone* Vol. 27 No. 1: 139-143, 2000.

Sudduth, K.A., Hummel J.W. Portable, near-infrared spectrophotometer for rapid soil analysis. *Transactions of the ASAE*. Vol. 36: 185-93, 1993.

Vico L., Collet P., et al. Effects of long-term microgravity exposure on cancellous and cortical weight-bearing bones of cosmonauts. *The Lancet* Vol. 355: 1607-11, 2000.

Yalow R.S., Berson S.A. Immunoassay of endogenous plasma insulin in man. *J Clin Invest* 39: 1157-75, 1960.

Yu W., E. Chang, R. Drezek, V. Colvin. Water-soluble quantum dots for biomedical applications. *BBRC* 348: 781-6, 2006.

Yu S.L., Ho L.M., Lim B.C., Sim M.L. Urinary deoxypyridinoline is a useful biochemical bone marker for the management of postmenopausal osteoporosis. *Ann Acad Med Singapore*, 27: 527-9, 1998.

Zhang H., Yee D., Wang C. Quantum dots for cancer and diagnostic therapy: biological and clinical perspectives. *Nanomedicine* 3: 83-91, 2008.



## I. Collaborators

### **Dr. Tara Ruttley** [JSC-EB]

Biomedical Systems Division  
NASA Johnson Space Center  
2101 NASA Road 1 - Houston, TX 77058  
Email: tara.m.ruttley@nasa.gov ph: (281) 483-9615

Dr. Ruttley is a member of the Biomedical Systems Division at NASA. Her previous work includes her role as Lead Hardware Engineer on the Health Maintenance System on the ISS.

### **Dr. David Tomko** – NASA Headquarters

Advanced Capabilities Division - Human Research Program  
NASA Johnson Space Center  
2101 NASA Road 1 - Houston, TX 77058  
Email: dtomko@nasa.gov ph: (202) 358-2211

Dr. Tomko is a member of NASA's Advanced Capabilities Division.

### **Vengadesan Nammalvar** – Rice University

Department of Bioengineering  
Email: venkyn@rice.edu  
Phone: (713) 348-2638

Vengadesan has been an invaluable resource for our nanoshell synthesis. He is a graduate student in Dr. Drezek's lab who is in charge of the lab's nanoshell research. He has already helped us to synthesize functioning nanoshells for our device.

### **Dr. Rebeka Drezek** – Rice University

Department of Bioengineering  
Email: drezek@rice.edu  
Phone: (713) 348-3011

Dr. Drezek has opened her lab for our use. We have used her equipment for nanoshell synthesis and plan to use her lab for testing our device. Her cooperation with our project has been critical to the building and testing of our device.

### **Dr. Susan A. Bloomfield** – Texas A&M University

Department of Health & Kinesiology and Intercollegiate Faculty of Nutrition Director of the Bone Biology Laboratory  
Email: sbloom@tamu.edu  
Phone: (979) 862-1181

Dr. Bloomfield will be an invaluable resource to the team. She specializes in bone biology under microgravity conditions. In addition to a tour of her research laboratory, she will be able to help determine the feasibility of the design.

**Dr. Nancy Butte** – Baylor College of Medicine

USDA/Agricultural Research Service's Children's Nutrition Research Center

Email: nbutte@bcm.tmc.edu

Dr. Butte will provide necessary insight pertaining to the urine assay component of the design. She has offered to give a tour of her laboratory as well as the laboratories of her colleagues so that the team can get a personal, in-depth understanding of the current detection methods used.

**Dr. Melissa Knothe-Tate** – Case Western Reserve University

Experimental and Computational Mechanobiology Laboratories

Email: knothead@case.edu

Phone: (216) 368-5884

Dr. Knothe-Tate holds a joint appointment in the Biomedical and Mechanical Engineering departments at CWRU. She is specifically focused on bone biology and the mechanobiological influences on bone, and has performed research regarding bone strength in microgravity. She will be a valuable resource for helping us to determine which bone degradable products will be most feasible to test.

**Dr. Adrian D. LeBlanc** – Baylor College of Medicine

Departments of Medicine and Orthopedic Surgery

Director of Division of Space Life Sciences

Email: leblanc@dsls.usra.edu

Phone: (713) 793-1131

Dr. LeBlanc is interested in building systemic bone loss monitoring device for use in space flight. His efforts focus primarily on imaging techniques, but his expertise would serve as a valuable resource to the design project.

**Dr. James F. Young and Dr. Richard Baraniuk** – Rice University

Department of Electrical and Computer Engineering

Email: young@ece.rice.edu and richb@rice.edu (respectively)

Phone: (713) 348-4721 and (713) 348-5685 (respectively)

Dr. Young and Dr. Baraniuk have extensive research interests in electrical engineering design that will be useful during the design process of the analysis component of the device. In particular, Dr. Baraniuk explores signal-processing algorithms that accommodate low power consumption for long-term battery operation. Dr. Young is an expert in the development of optical devices, which is useful for the development of the optical device.